



distretto culturale evoluto piceno

DESIGN DEL **B**ELLO **B**UONO **B**ENFATTO

design

orkshop

IL MERCHANDISING PER LA VALORIZZAZIONE DEL MUSEO DEL MARE DI SAN BENEDETTO DEL TRONTO: IPOTESI PROGETTUALI

07.10.2015 | PRESENTAZIONE DEI RISULTATI FINALI DEL WORKSHOP ORGANIZZATO DALLA S.A.D. IN COLLABORAZIONE CON IL COMUNE DI SAN BENEDETTO DEL TRONTO (GIUGNO - LUGLIO 2015)

partner:



coordinamento: L. Pietroni

designer guida: M. Elia, M. G. Fioravanti, A. Di Stefano, D. Galloppo e J. Mascitti

partecipanti: M. Amurri, M. Balsamo, M. Biondi, M. Chiappini, G. Di Cesare, A. Franconi, M. Gaspari, A. Mascitti, V. Menichelli, D. Paciotti, A. Scipi, L. Tafuri

il design 2.0 per le 3B del piceno
la valorizzazione dei patrimoni culturali del Bello, Buono e Benfatto

a cura di: Lucia Pietroni, Carlo Vinti, Federico O. Oppedisano e Daniele Rossi



Scuola di Architettura e Design "E. Vittoria" - Università di Camerino
Workshop 22-26 giugno | 6-10 luglio 2015

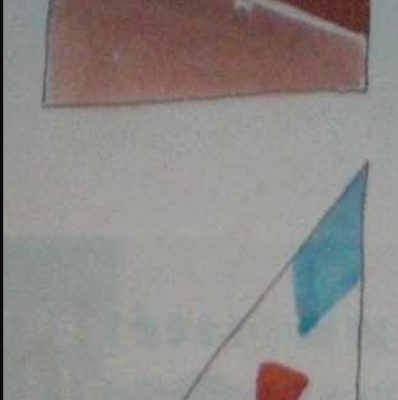

*mare scappa
ie pèsce de m
la miye giuv*



FAUNA MARINA

VELE

ANFORE

PARANZA

DETTI
DIALETTALI

FORMELLE
E SPOLETTA

COLTELLO
DEL RETARO

MASA

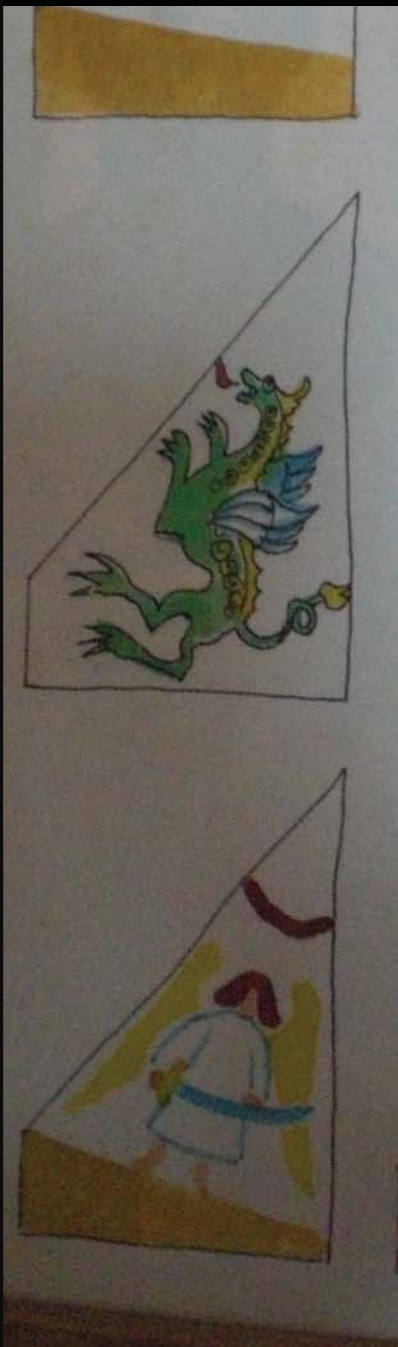

*rba parò che
rie se contru*

Arbé, da lu p

ocche, uje térr

*a le Gròtte
a Marà a m*

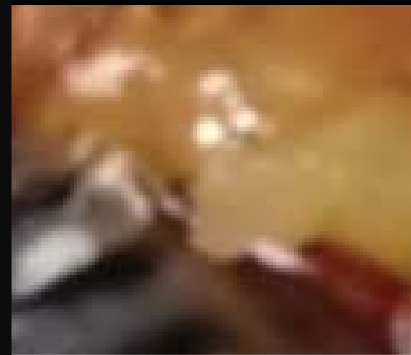
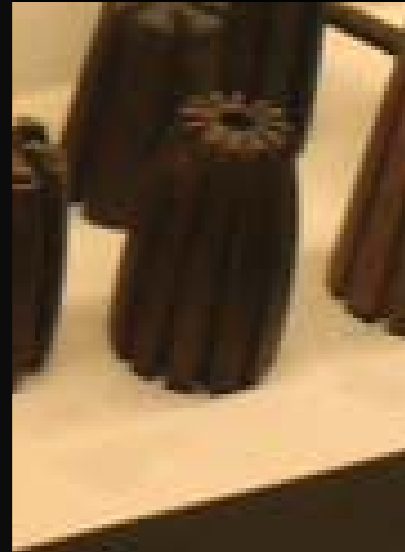



FAUNA MARINA

cappucci gommosi | cancelleria



adattabili alle
più comuni matite



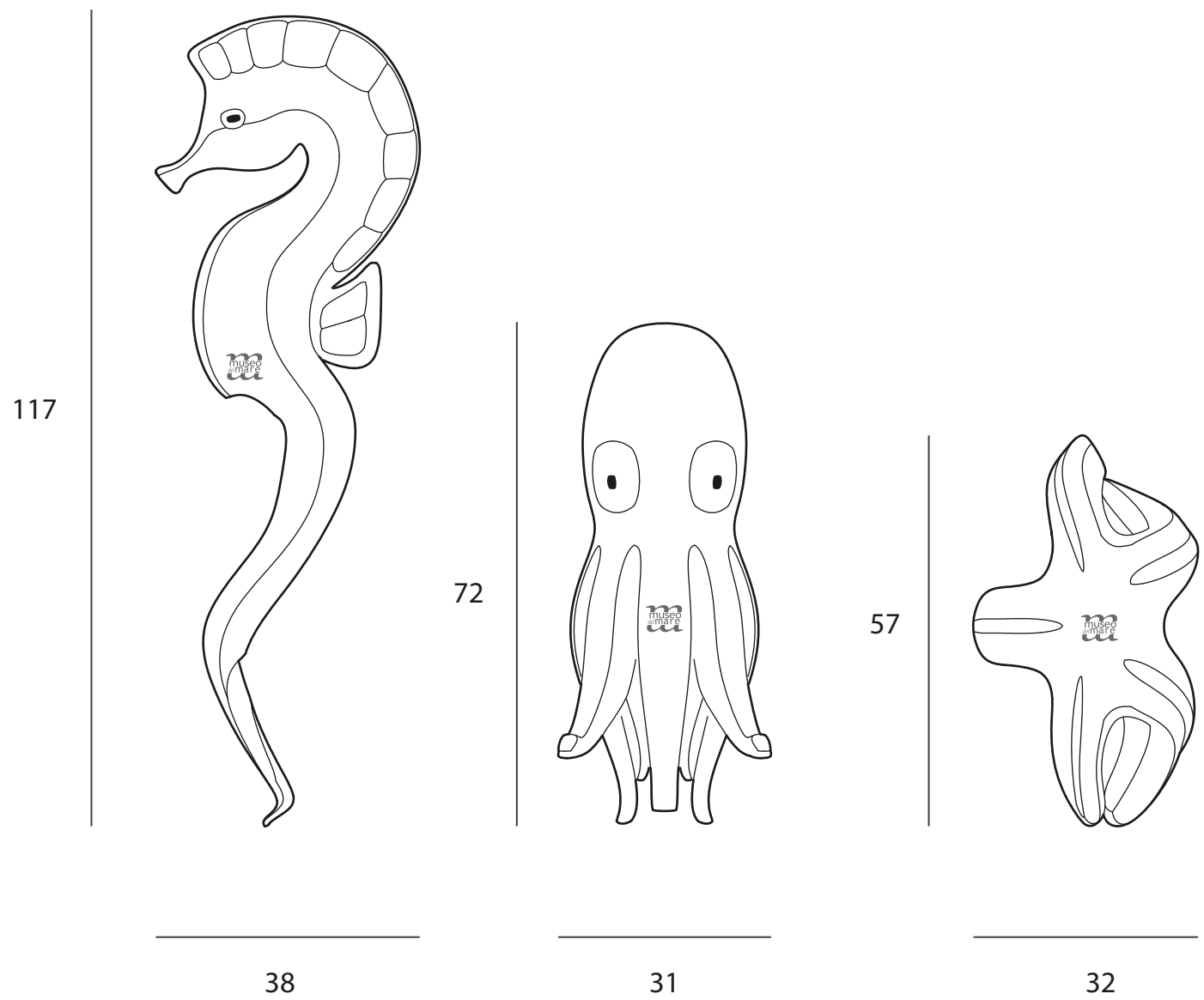

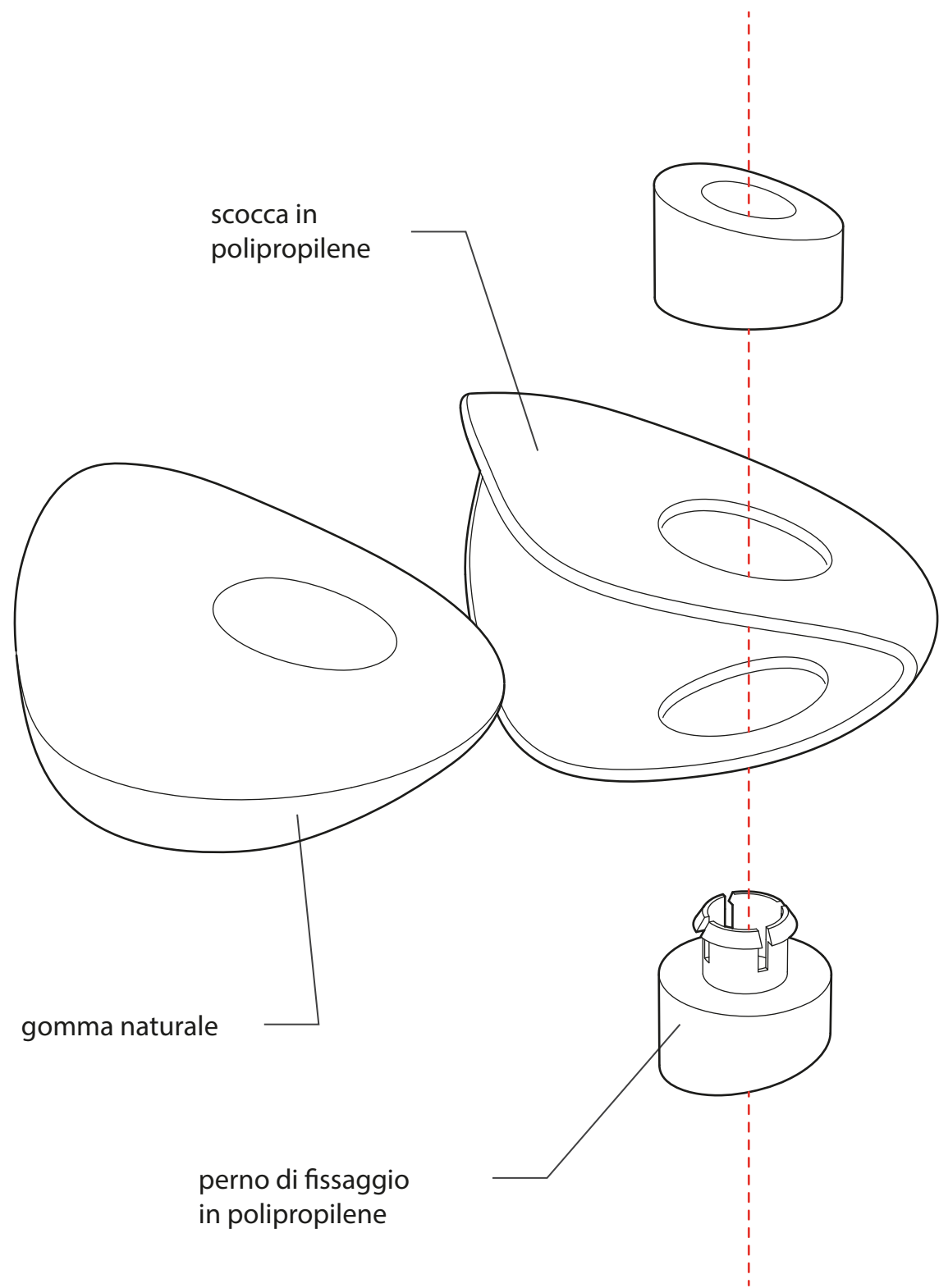



COZZA

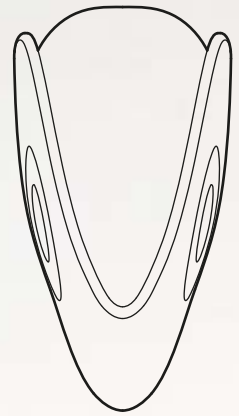

42

71



VONGOLA

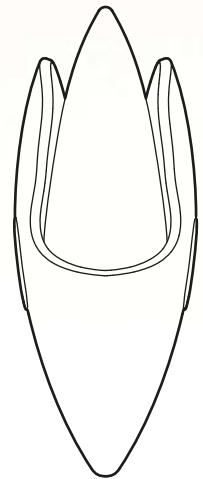

49

51



TELLINA



24

42





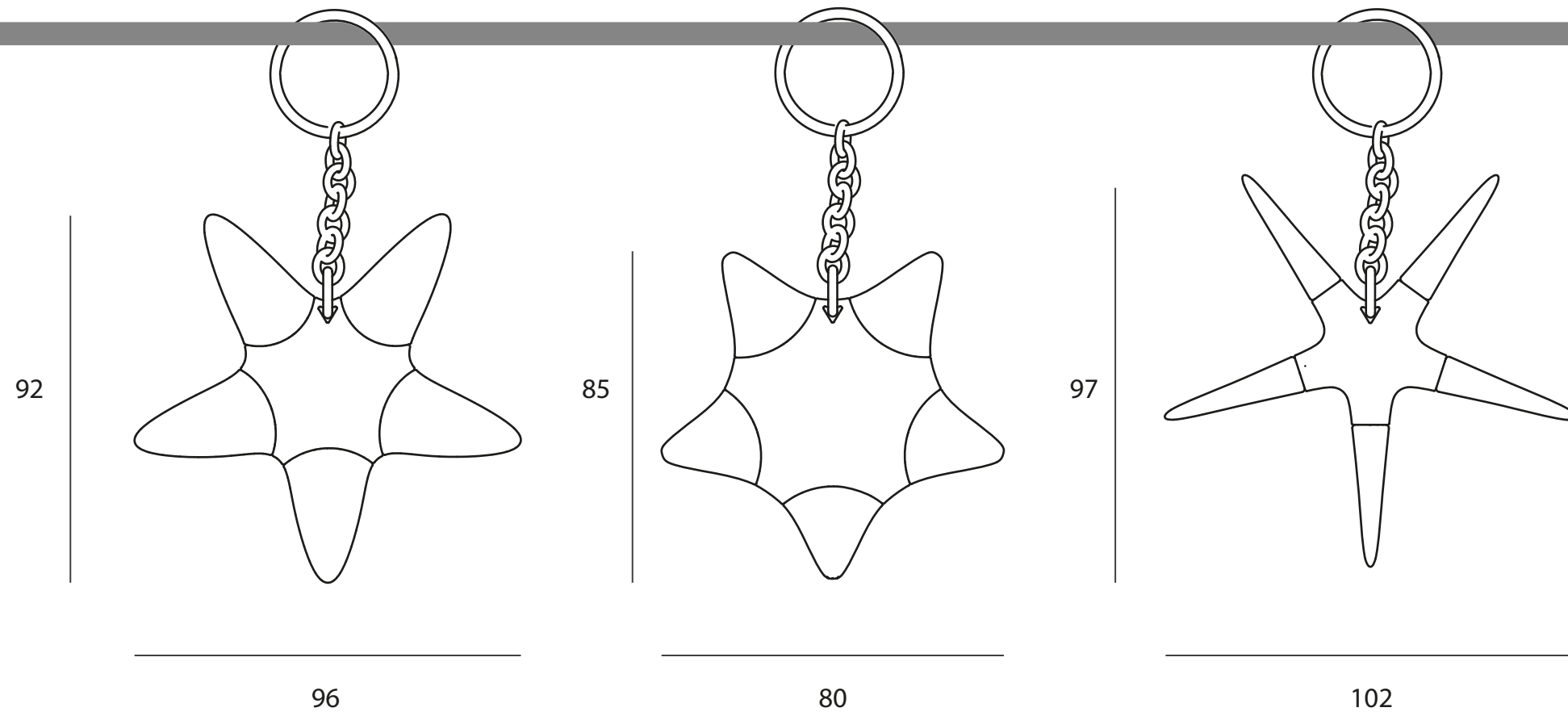



medusa

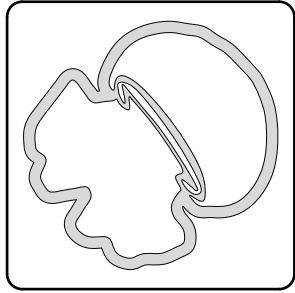

squalo

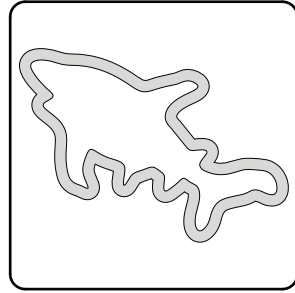

polipo

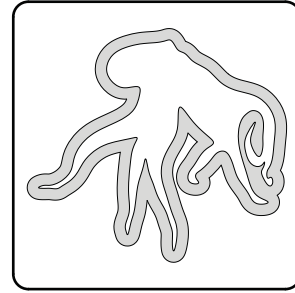

granchio

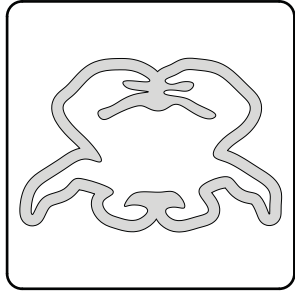

stellina

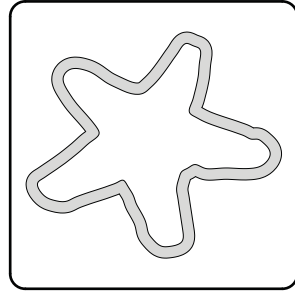

conchiglia

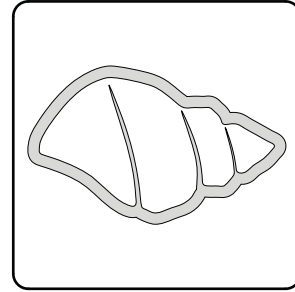

tartaruga

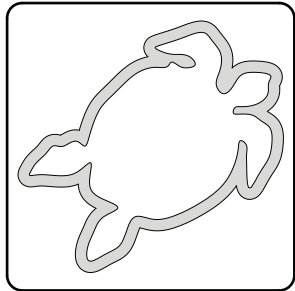

spada

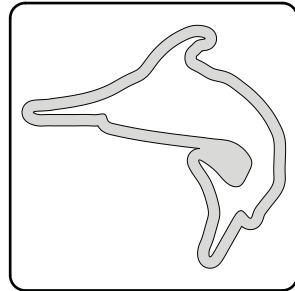

pesce

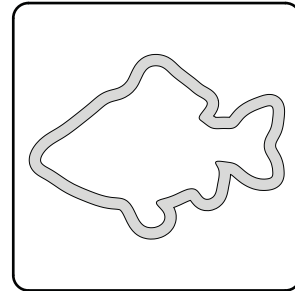

razza

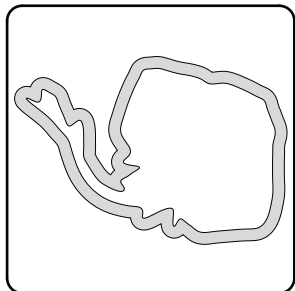

cavalluccio

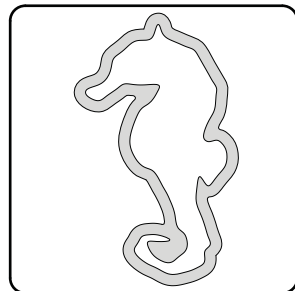

delfino

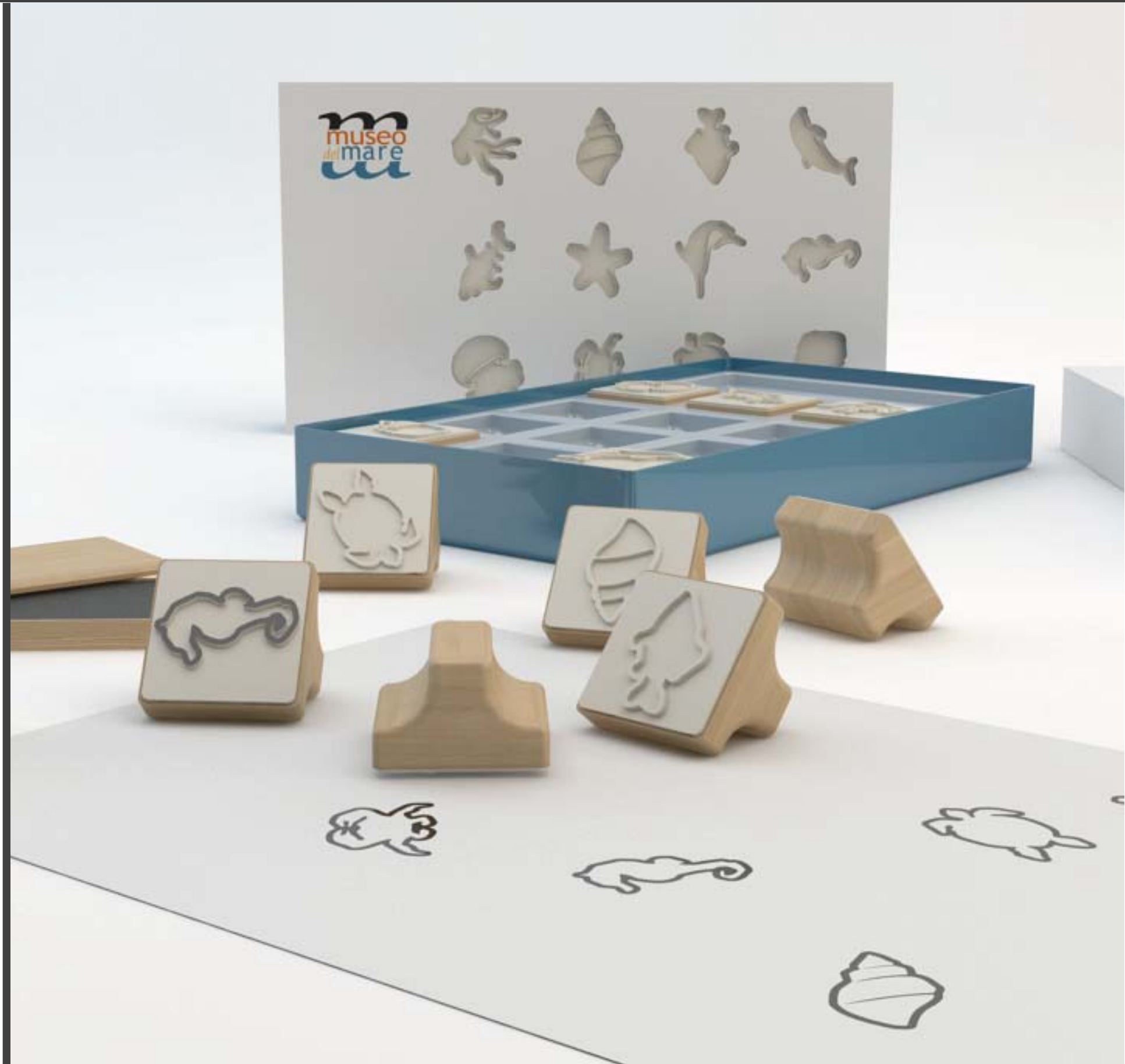
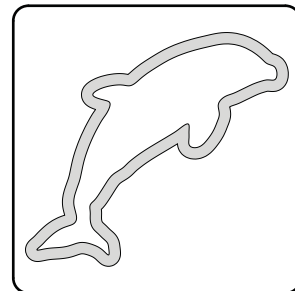

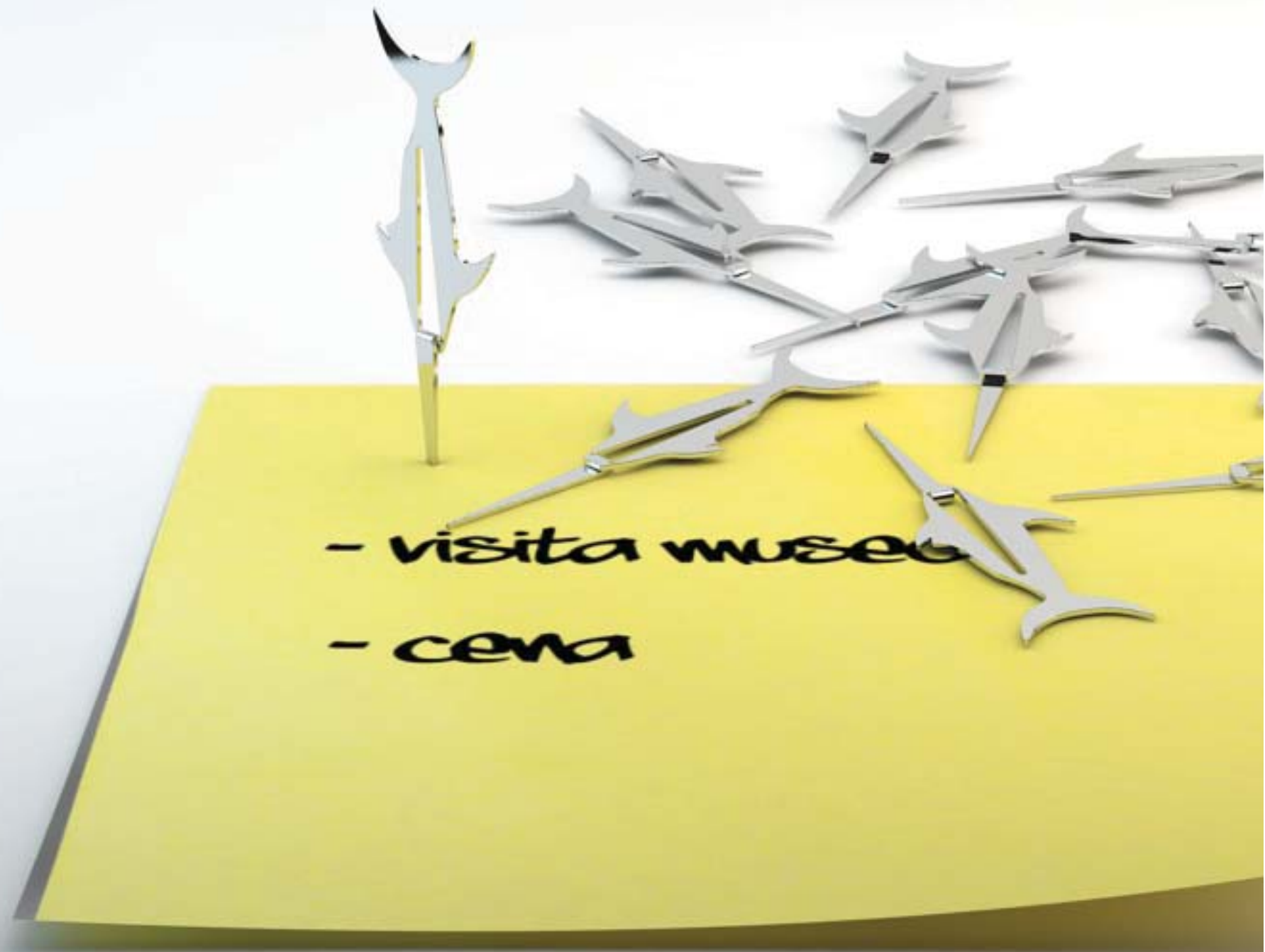
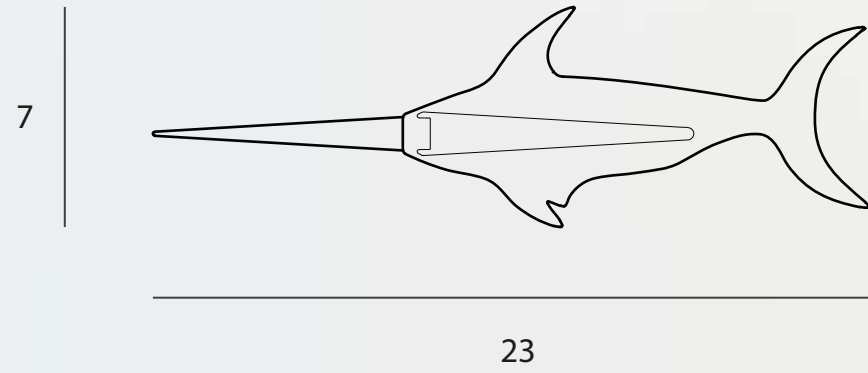

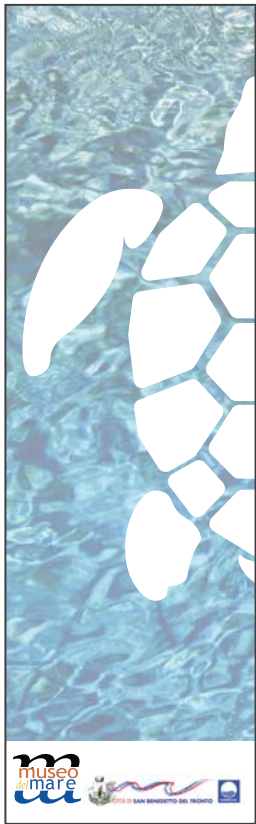
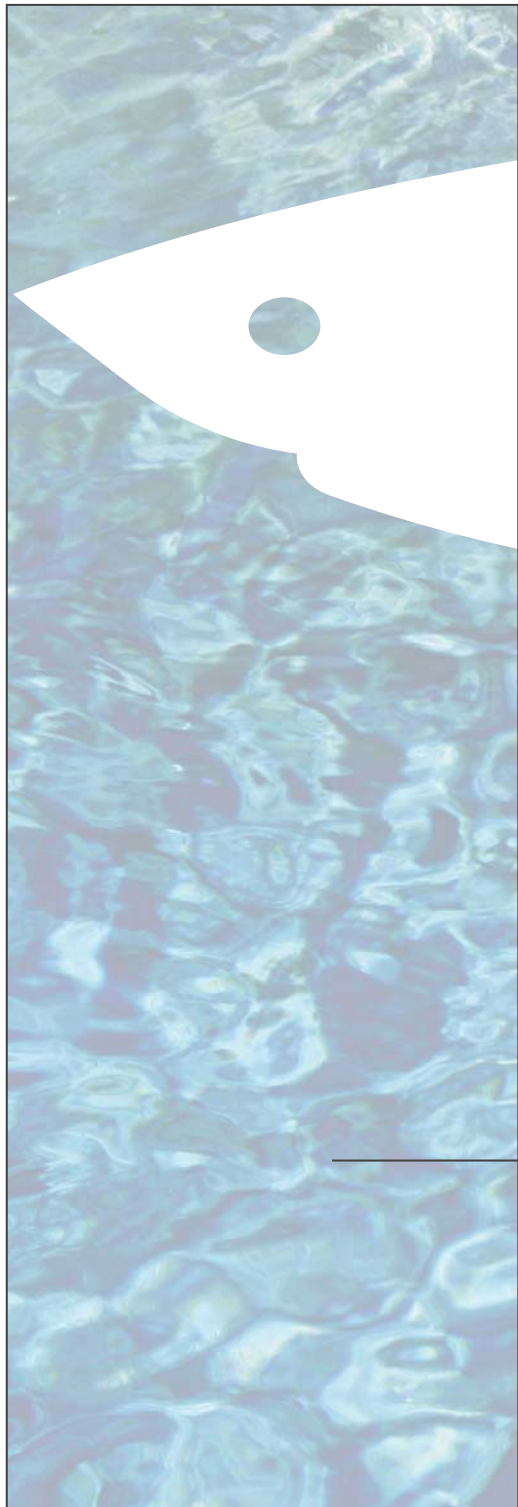

riproduce la texture
del mare sul libro

foglio di acetato
serigrafato

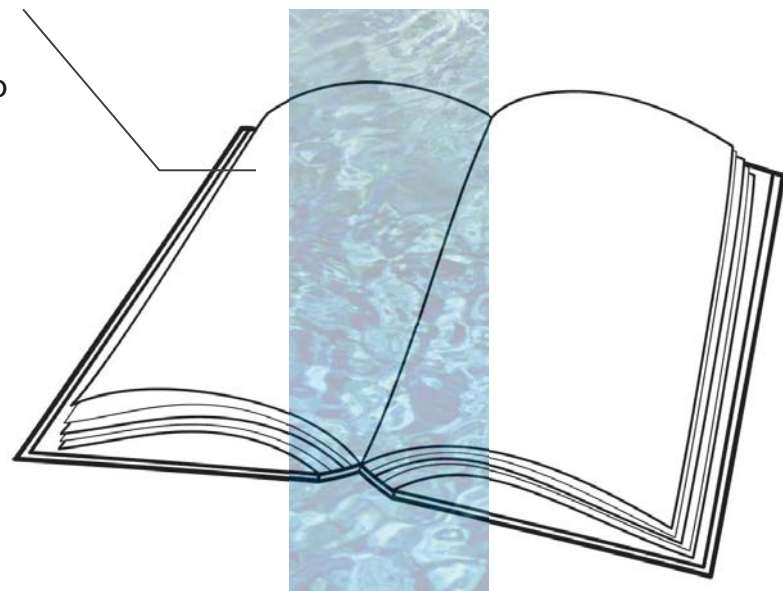

72

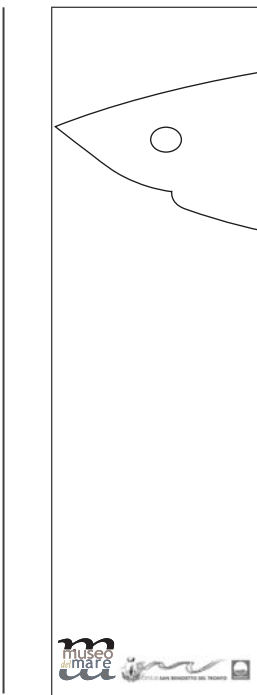

55

Indians are entirely... is entirely... hy and un... tion would... most fertile... g canal has... es not even... griculture of... nits, a hun... scanty, since... nts to 22,000... pon the zem... nts, amounts... oducts, it will... The ryots, or... emindars, are... t here, where... g waste, the... e of extreme... dia Company... nder its exclu... prosperity of... en I expressed... generally met... ericans, apolo... ound it so."... o India is an... be considered... past ten years... nicipal varieties

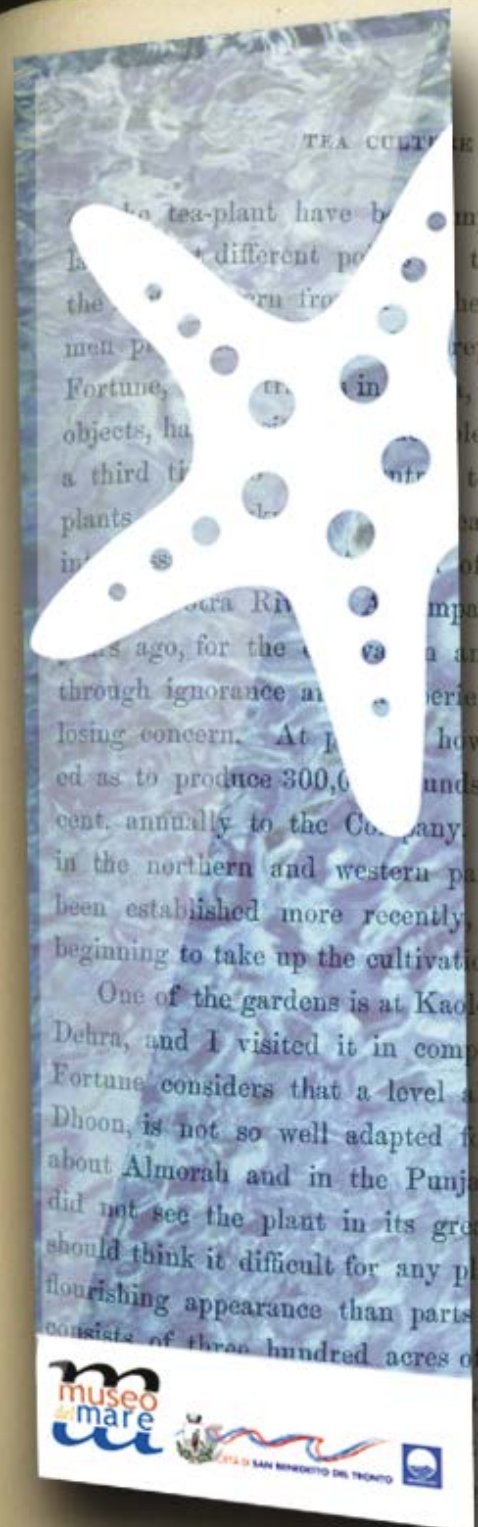

...the tea-plant have been imported, experimental gardens... the Himalayas, from Assam to... the Punjab, and Chinese work... preparation of the leaves. Mr. Fortune, on his mission to effect these objects, had... notice, had been dispatched a third time to procure fresh supplies of tea plants. The tea plant was first introduced of Bengal and lying on the... company was formed about fifteen years ago, for the... and manufacture of Tea; but through ignorance and... experience, it was for some time a losing concern. At present, however, it has so far succeeded as to produce 300,000 pounds of Tea, and to pay 10 per cent. annually to the Company. The experimental gardens in the northern and western parts of the Himalayas have been established more recently, and the natives are now beginning to take up the cultivation of the plant. One of the gardens is at Kaologir, about three miles from Dehra, and I visited it in company with Mr. Keene. Mr. Fortune considers that a level alluvial soil, like that of the Dhoon, is not so well adapted for tea as the hilly country about Almorah and in the Punjab, and if he be correct I did not see the plant in its greatest perfection; though I should think it difficult for any plantation to present a more flourishing appearance than parts of that at Kaologir. It consists of three hundred acres of level ground—a rich, dark... plants in every stage... the thick, bushy shrub, six... the next



'era una volta,

in un paese molto lontano,
un re che aveva undici figli maschi e una figlia, Elisa.
I principini conducevano una vita felice: andavano a scuola con la spada al fianco e scrivevano con penne di diamante.
Dal canto suo, la piccola Elisa leggeva su un libro meraviglioso, che da solo valeva quanto la metà del regno.
Ma presto quella vita felice ebbe fine.

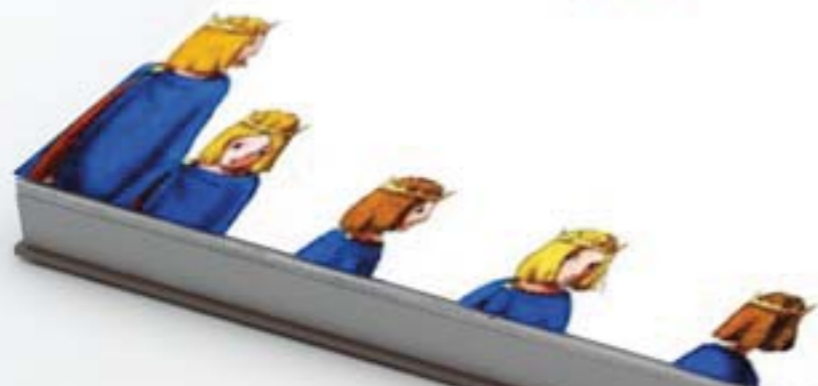

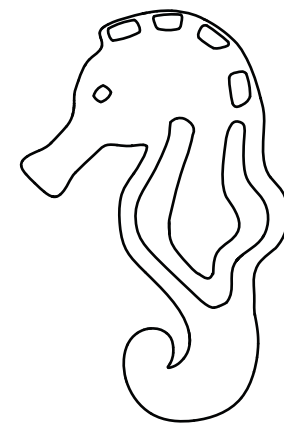

23



23

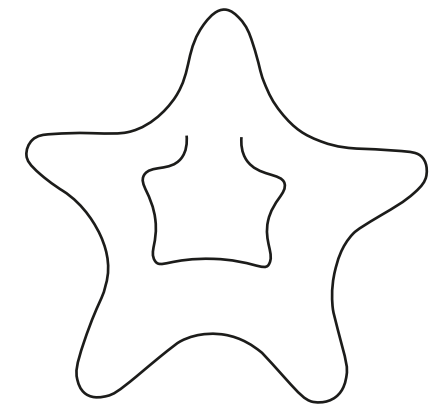

23

23

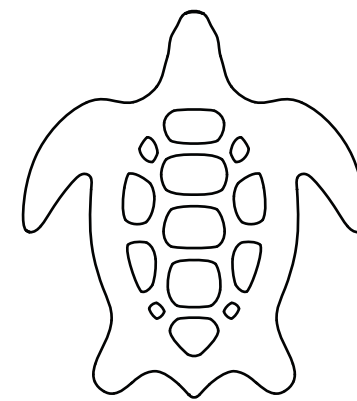

23

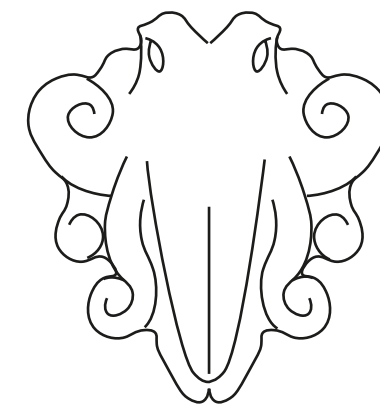

23

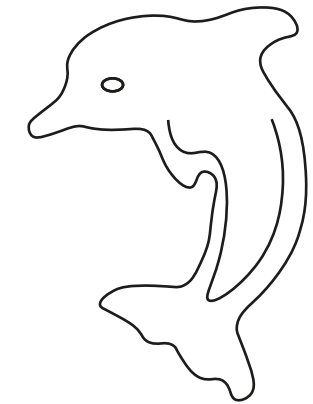

23

23

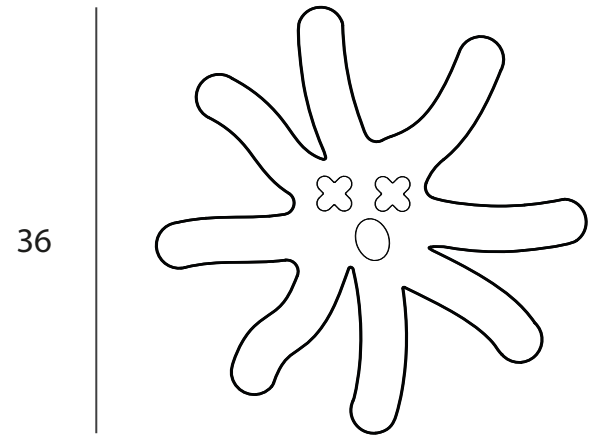

36

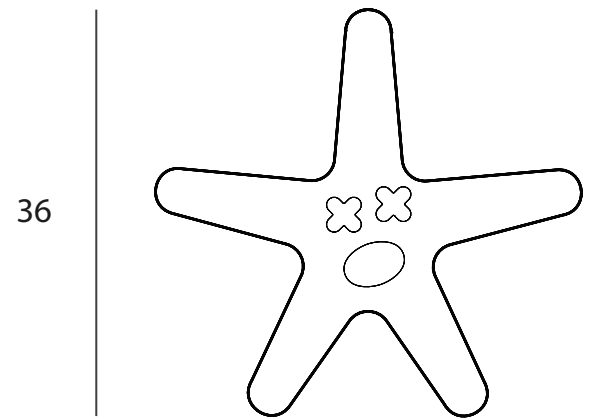
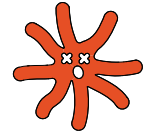
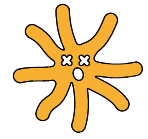

36

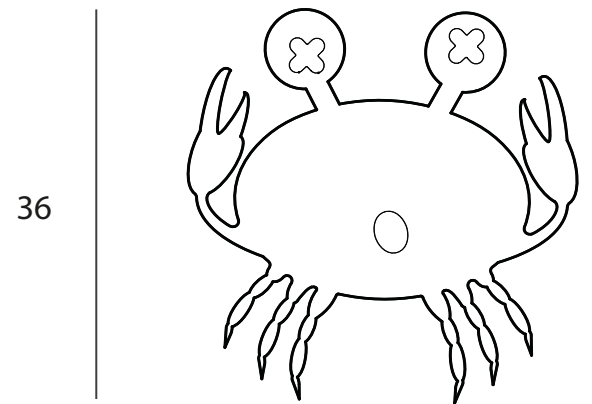

36

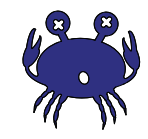
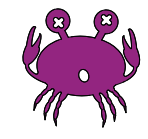
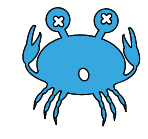

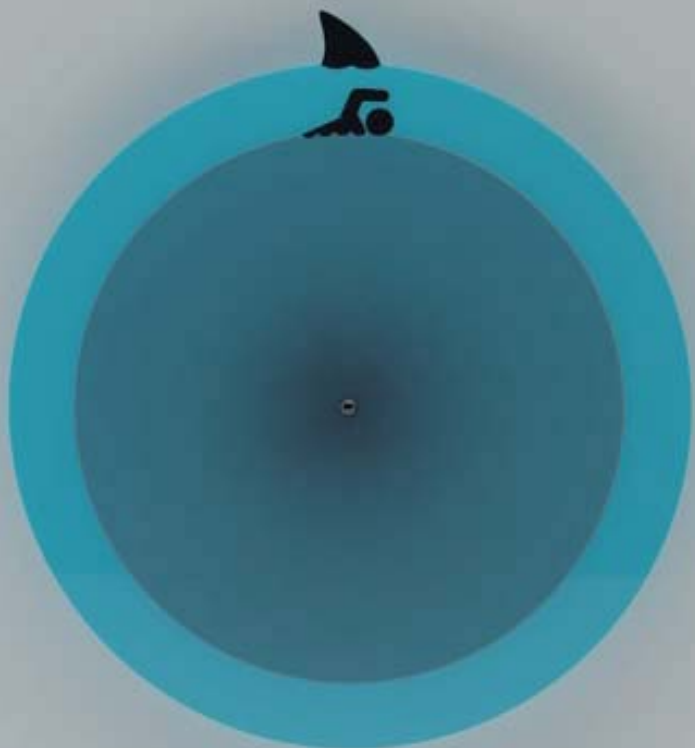
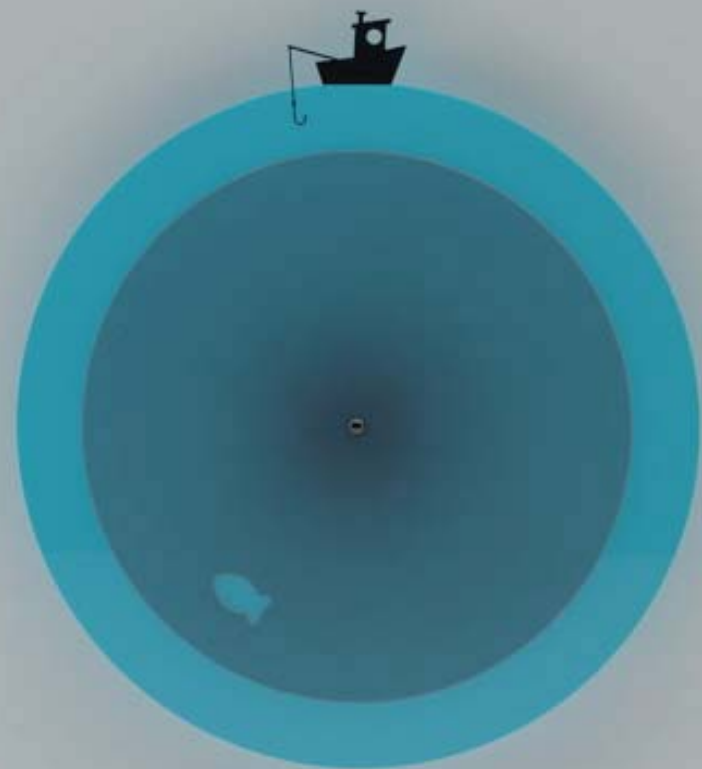

11.00

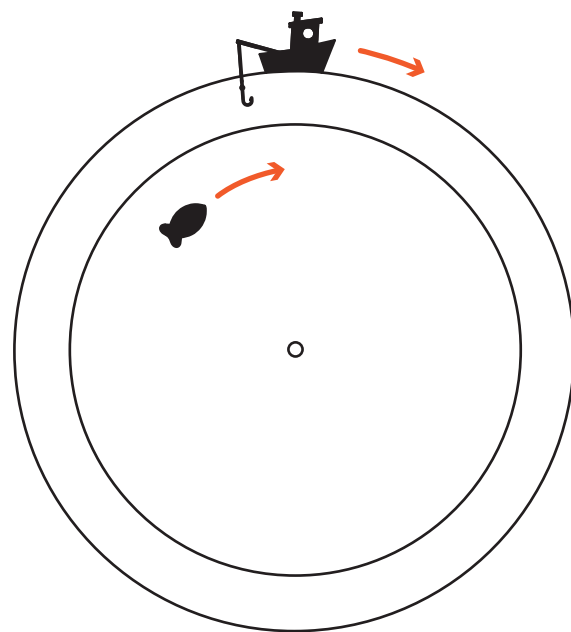

09.20

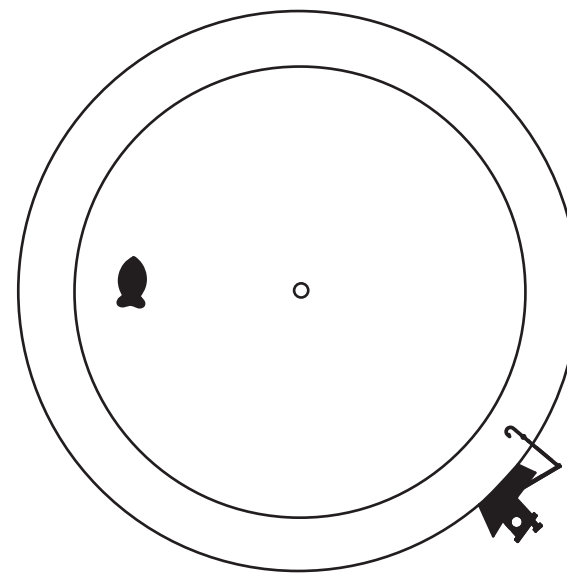

03.05

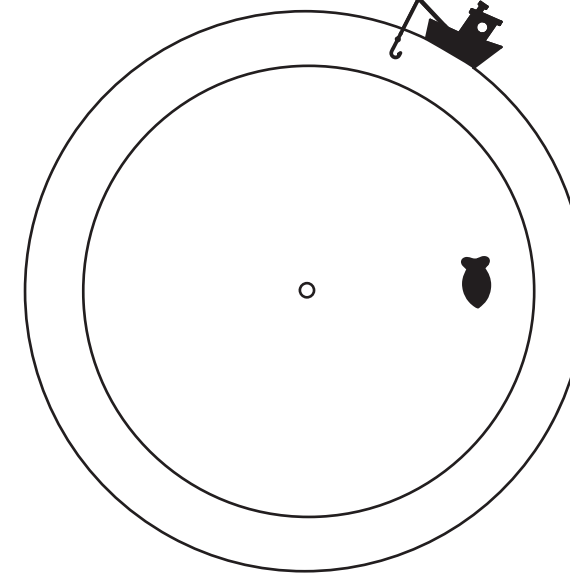

243

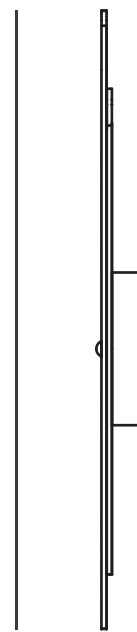

08.10

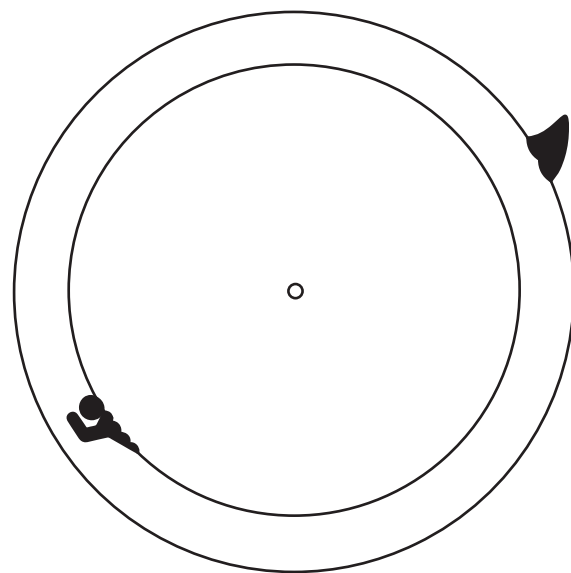

11.00

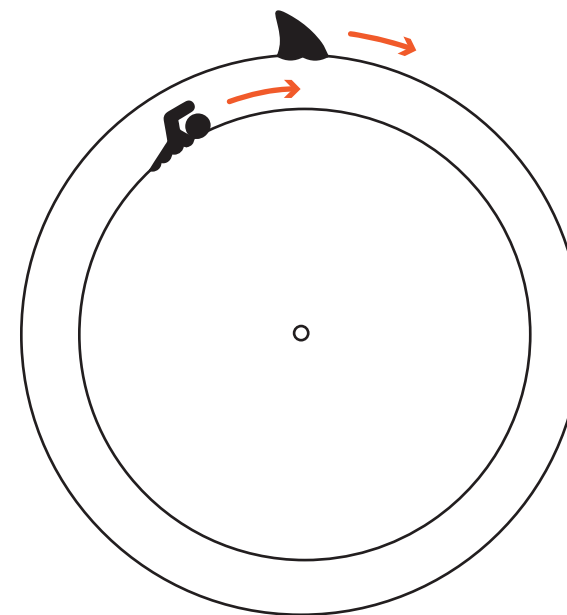

4.15

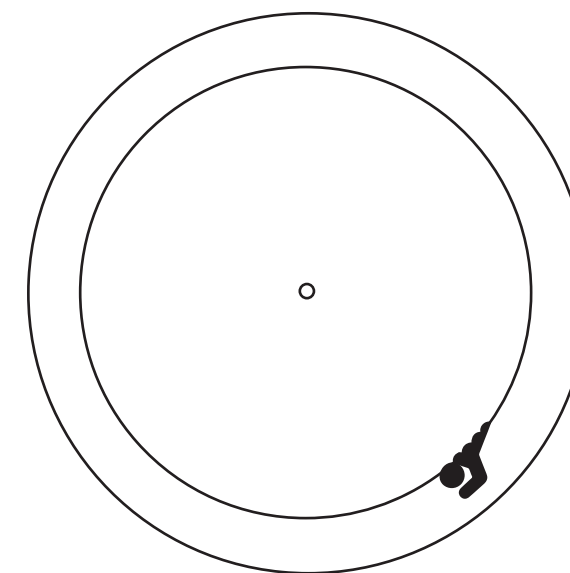

243

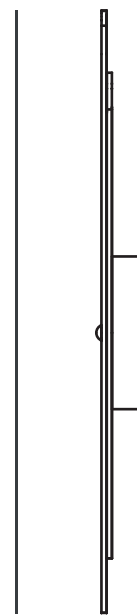

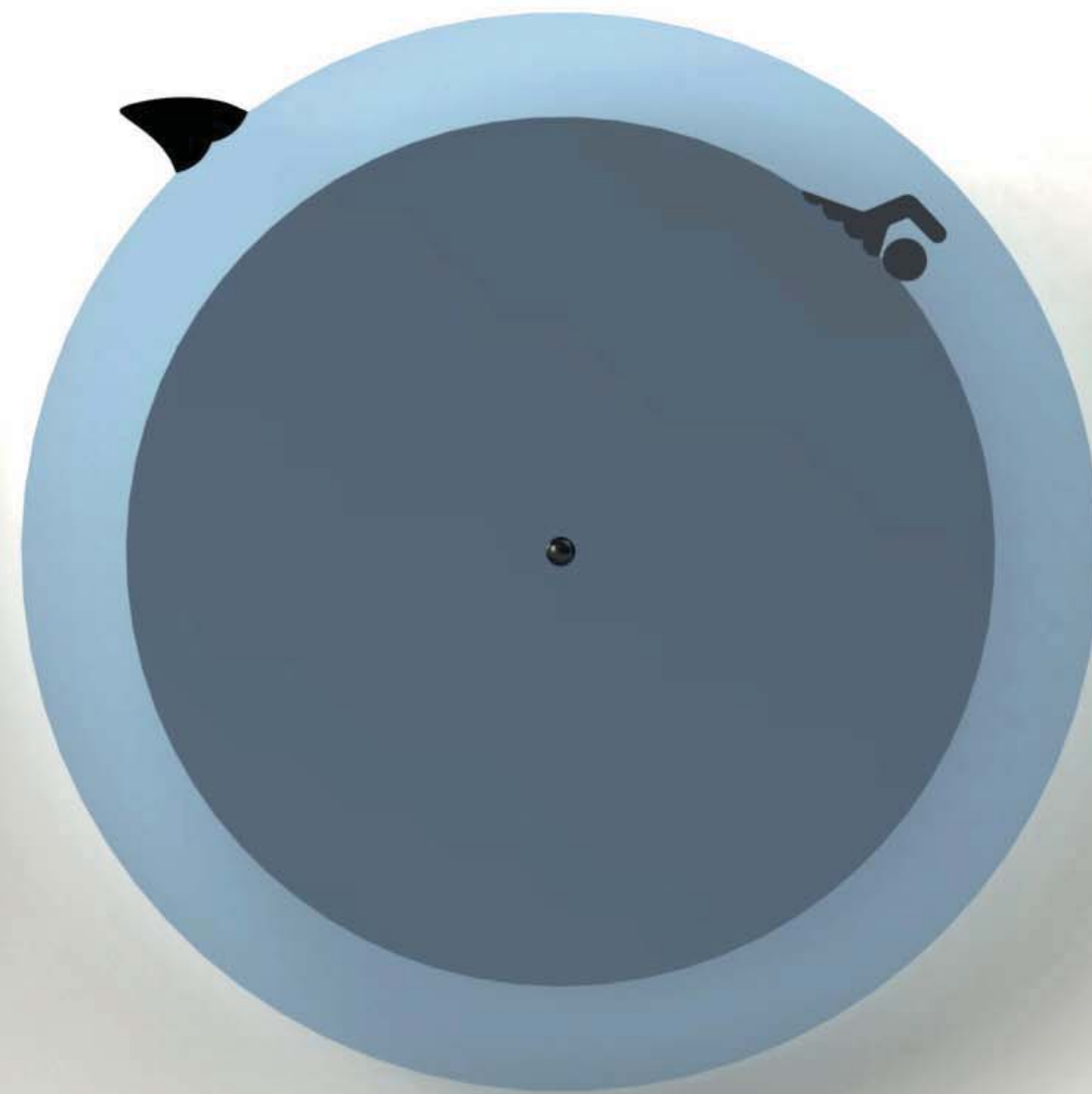
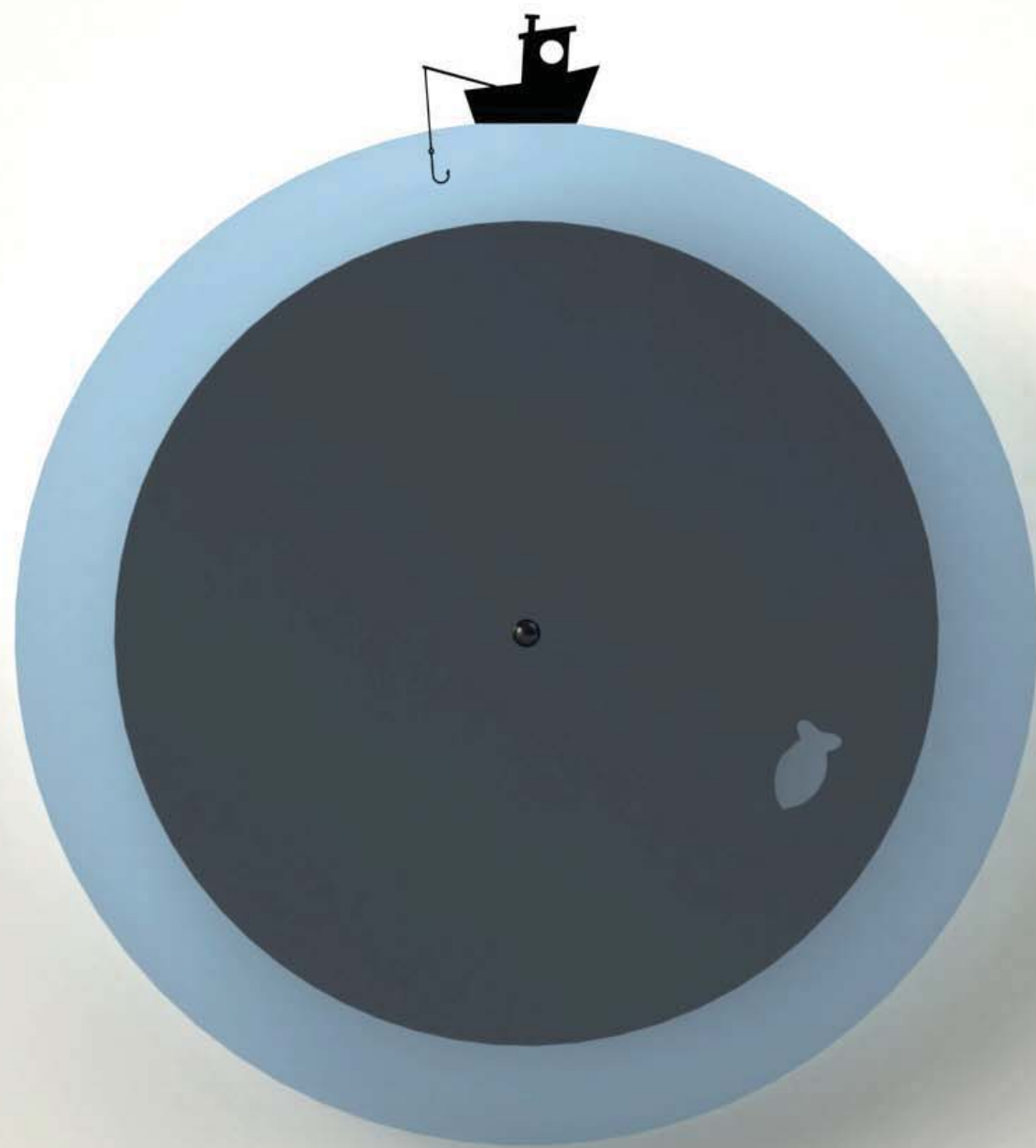



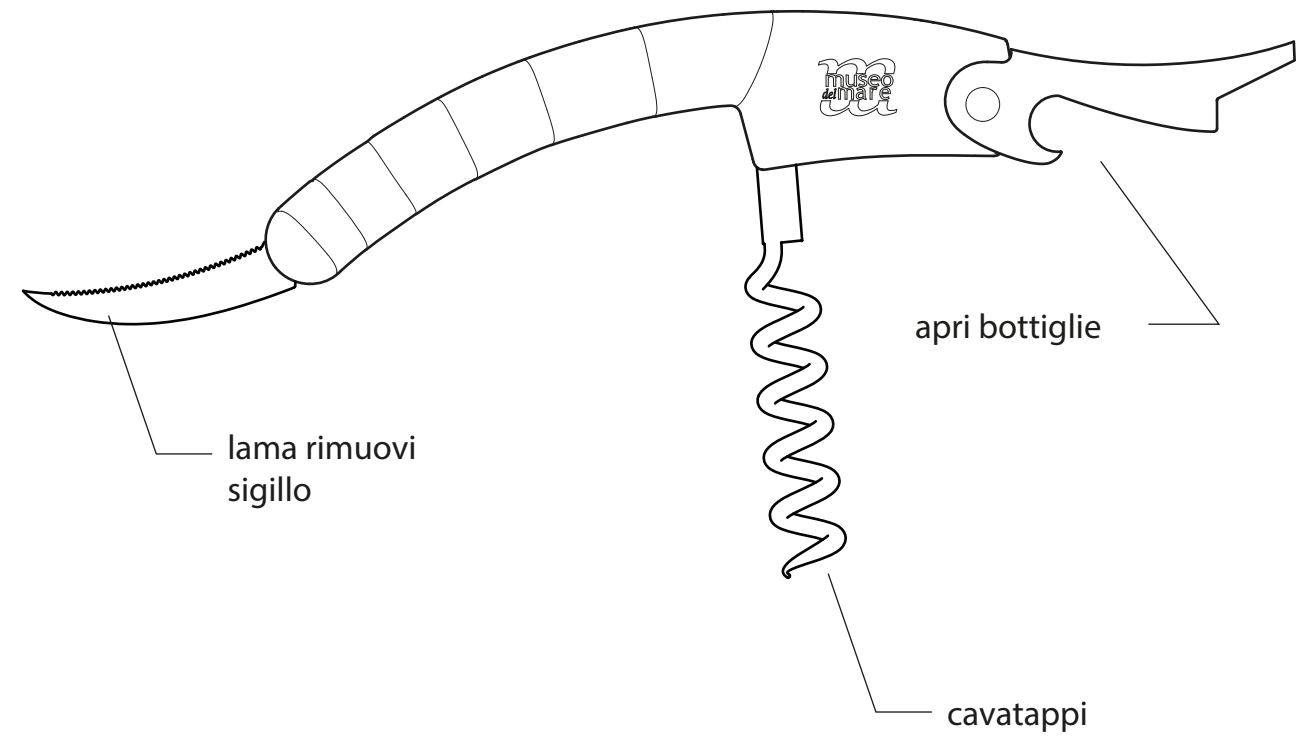
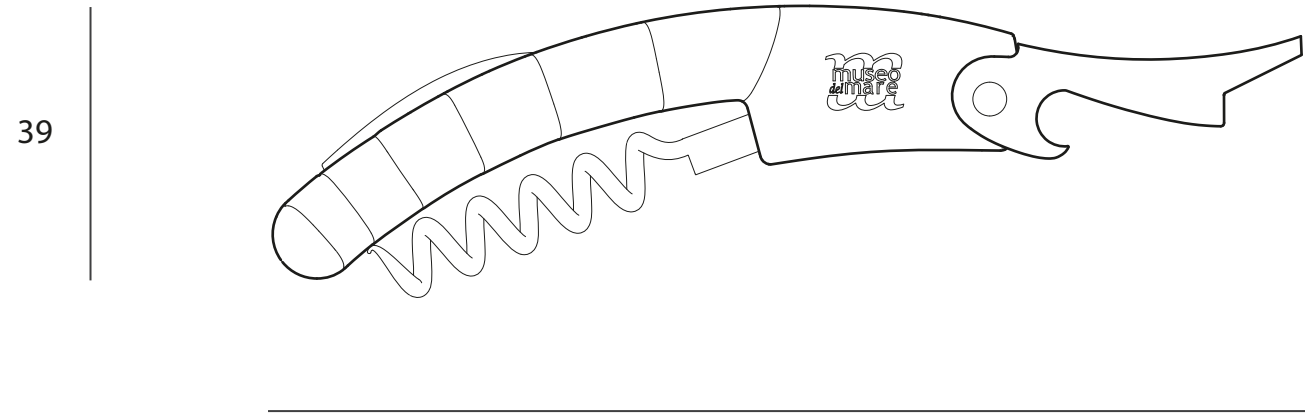







GAMMA

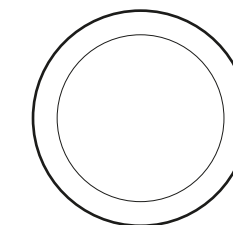

180

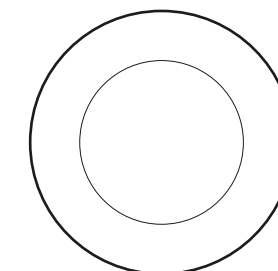

200

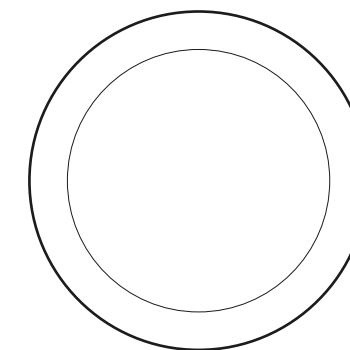

240

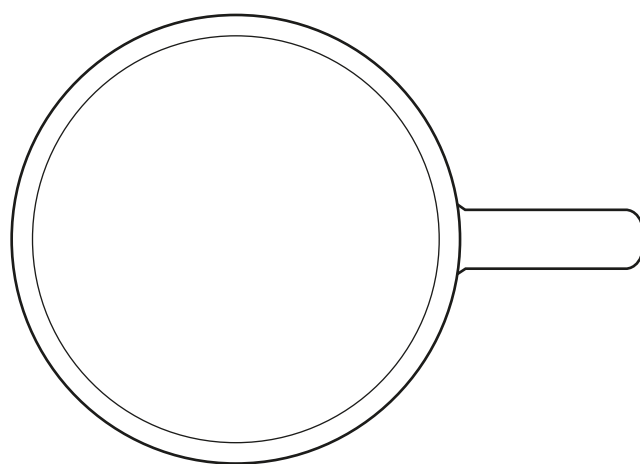
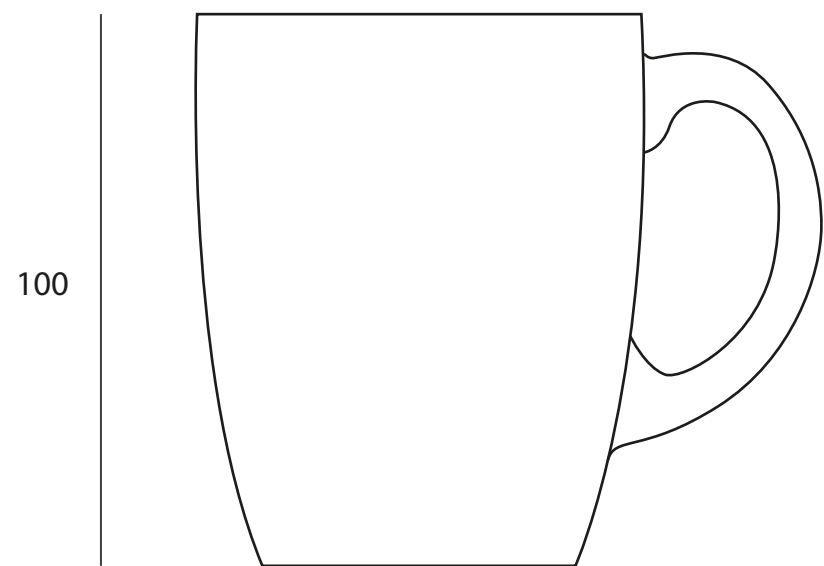

110



T-shirt donna | abbigliamento



T-shirt e felpa uomo | abbigliamento





POLPO STYLE



TARTARUGA STYLE



SGOMBRO STYLE



T-shirt | sgombro style

UOMO (FRONTE)

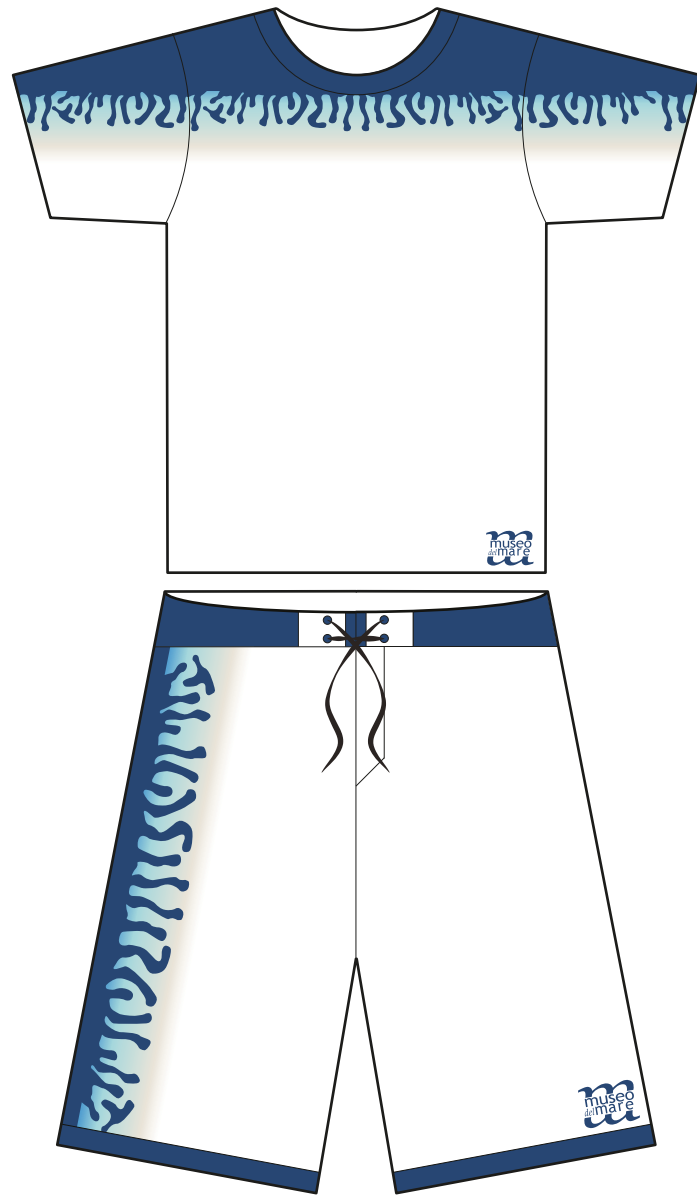

UOMO (RETRO)

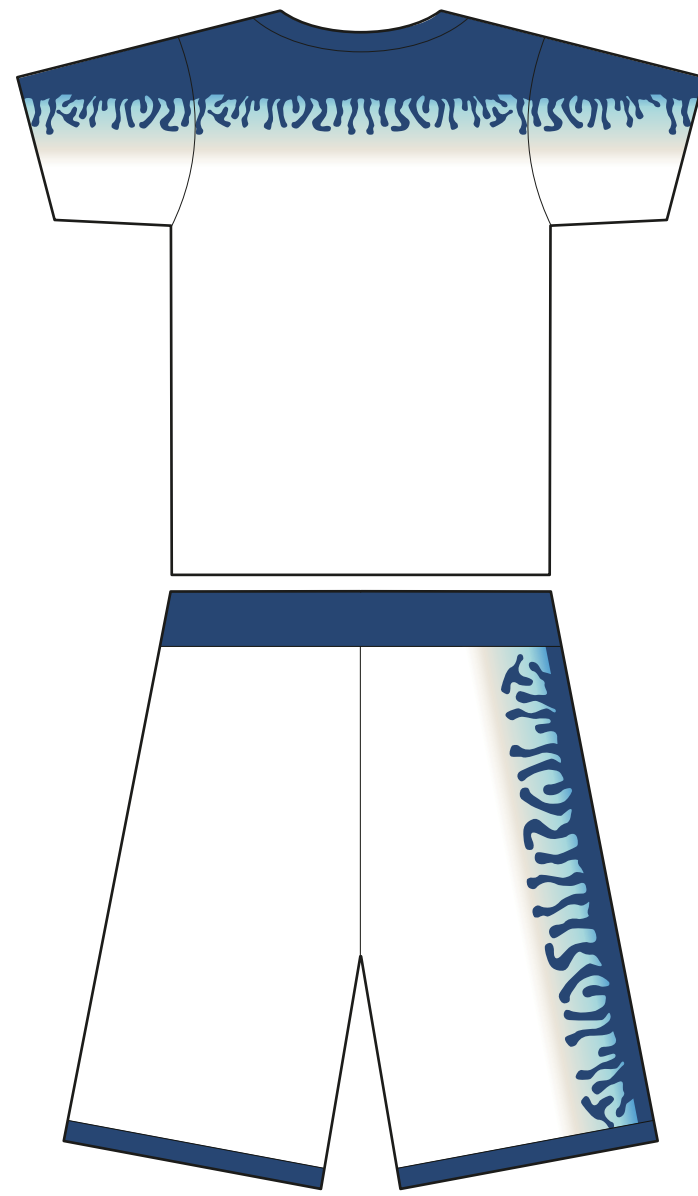

DONNA (FRONTE)



DONNA (RETRO)

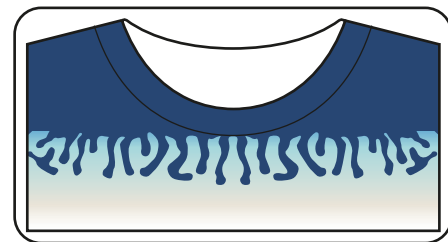
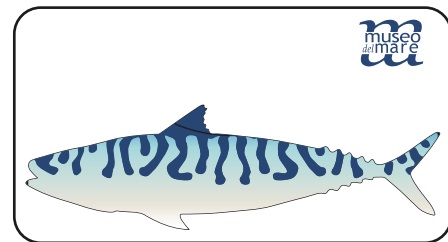

PACKAGING

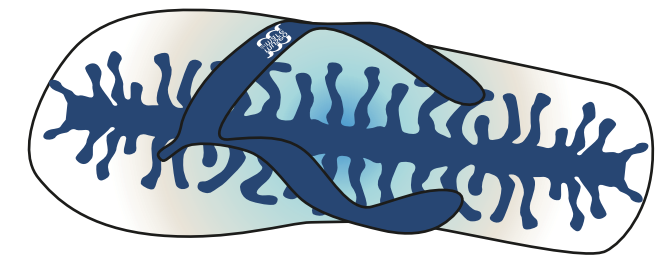
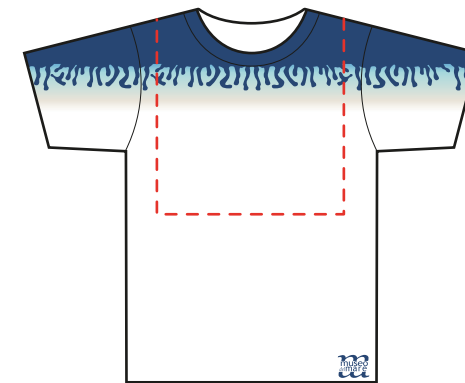

INFRADITO

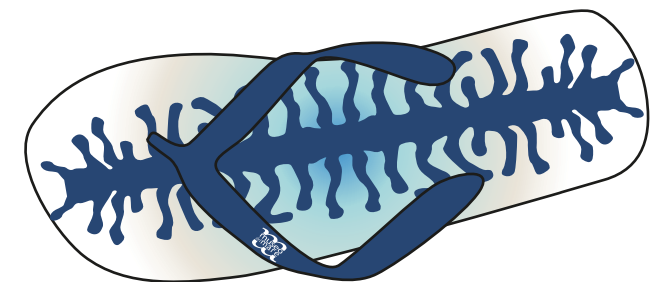

T-shirt | tartaruga style

UOMO (FRONTE)

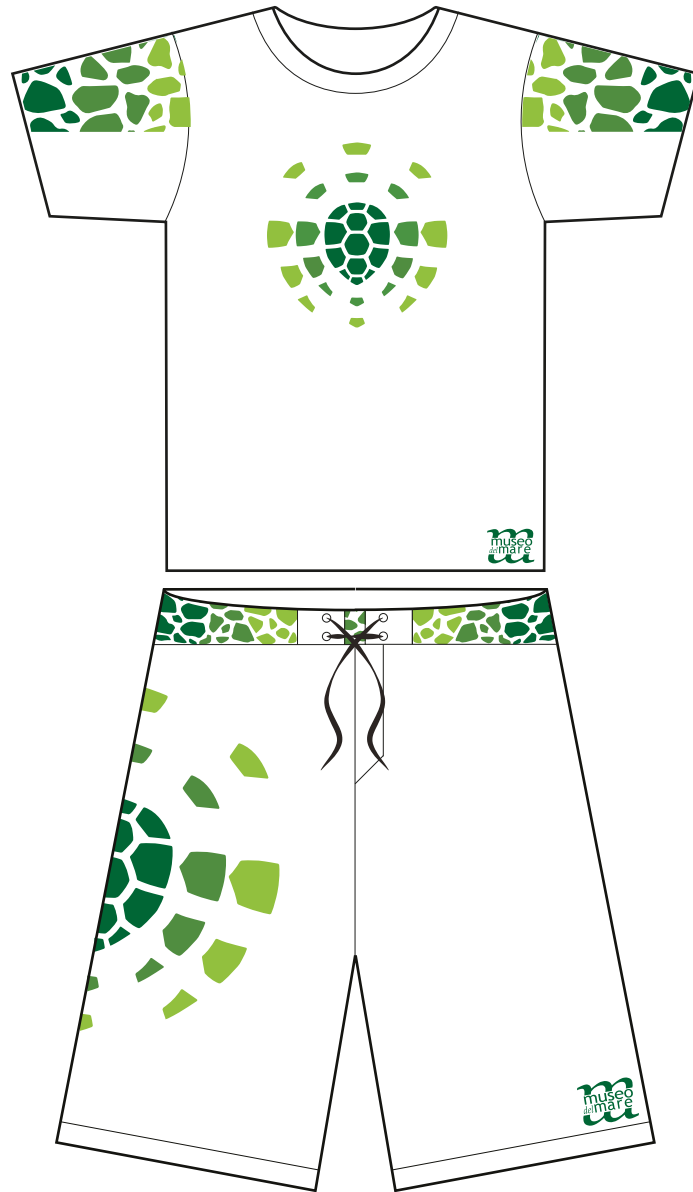

UOMO (RETRO)

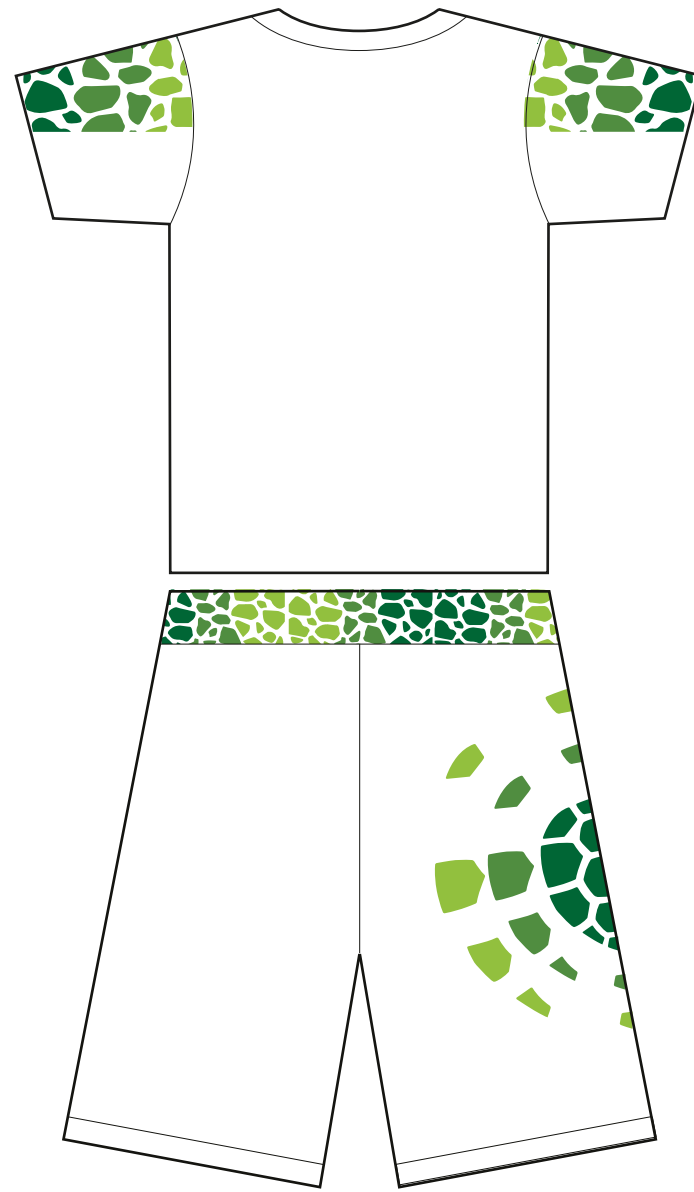

DONNA (FRONTE)

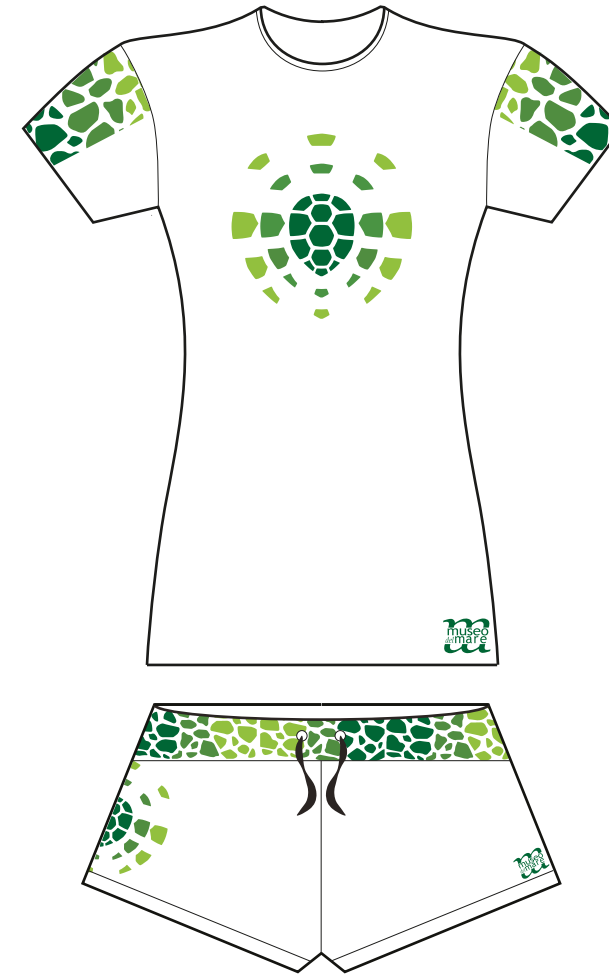

DONNA (RETRO)

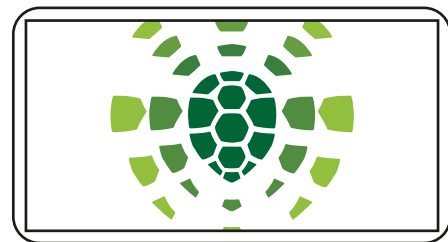
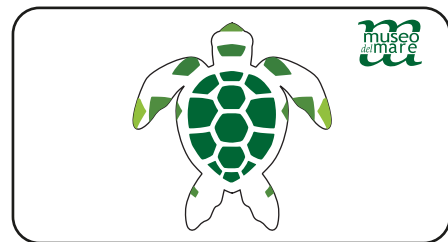
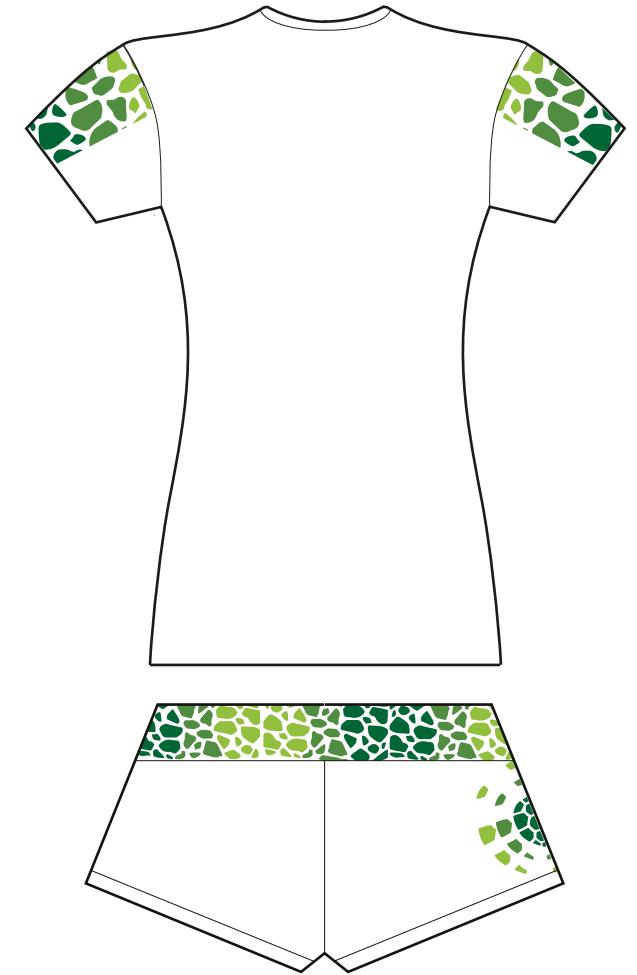

PACKAGING

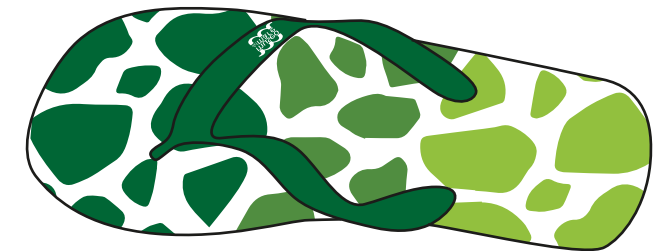
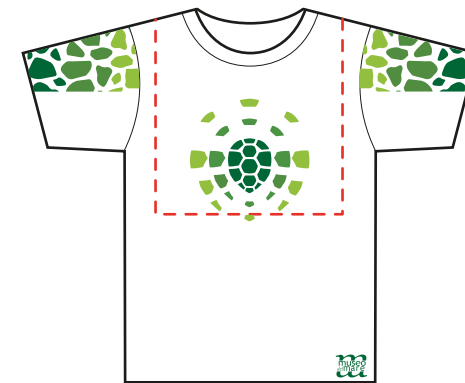

INFRADITO

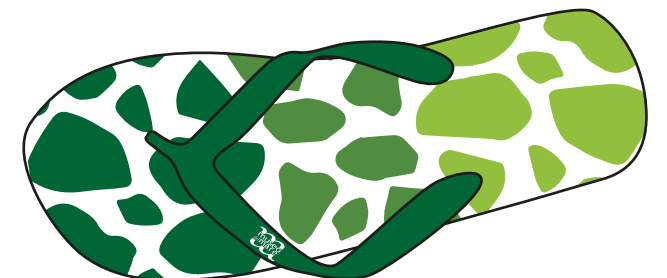

T-shirt | polpo style

UOMO (FRONTE)

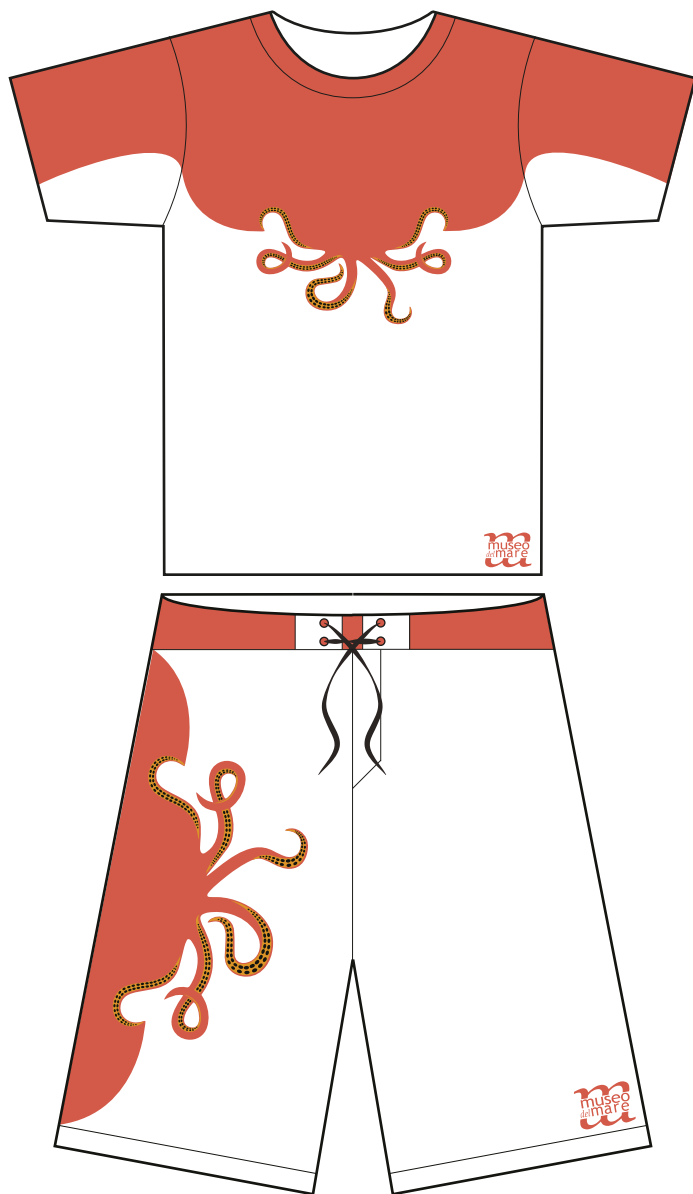

UOMO (RETRO)

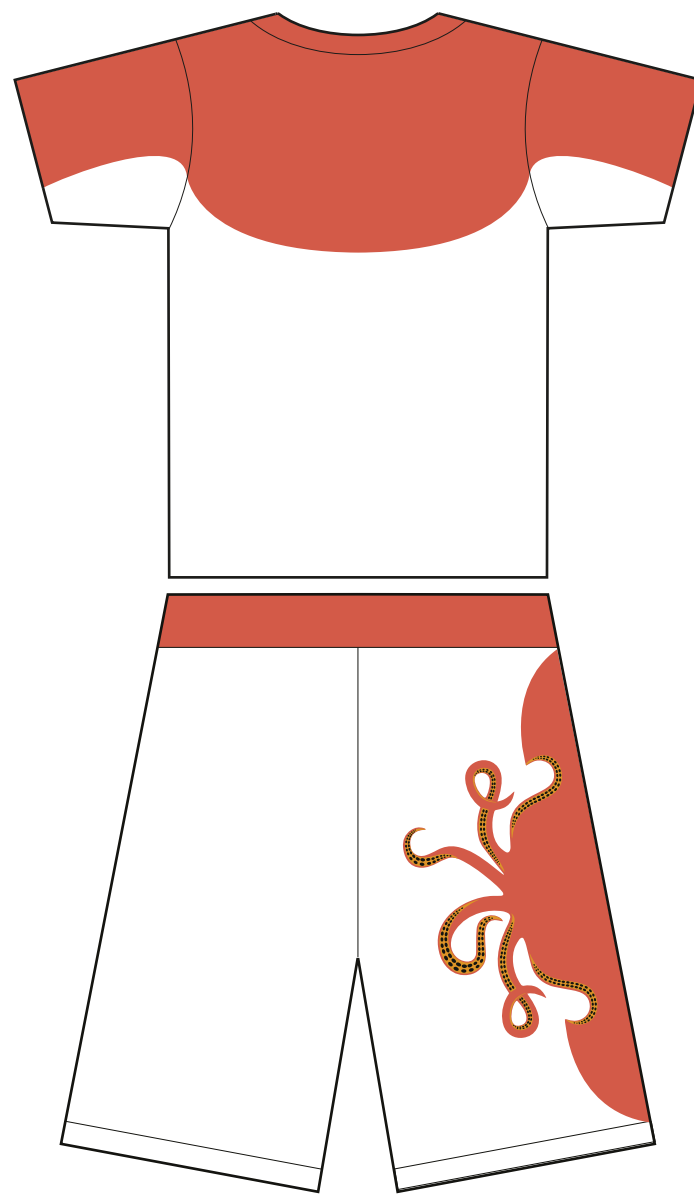

DONNA (FRONTE)



DONNA (RETRO)

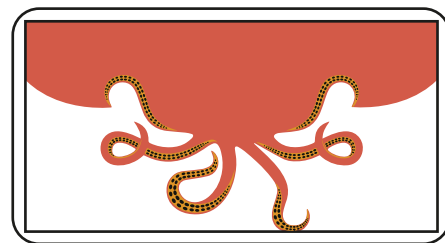
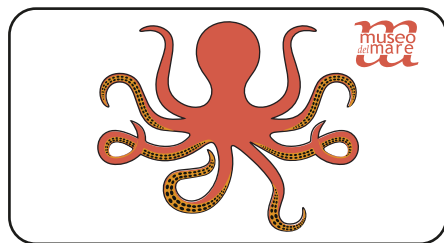
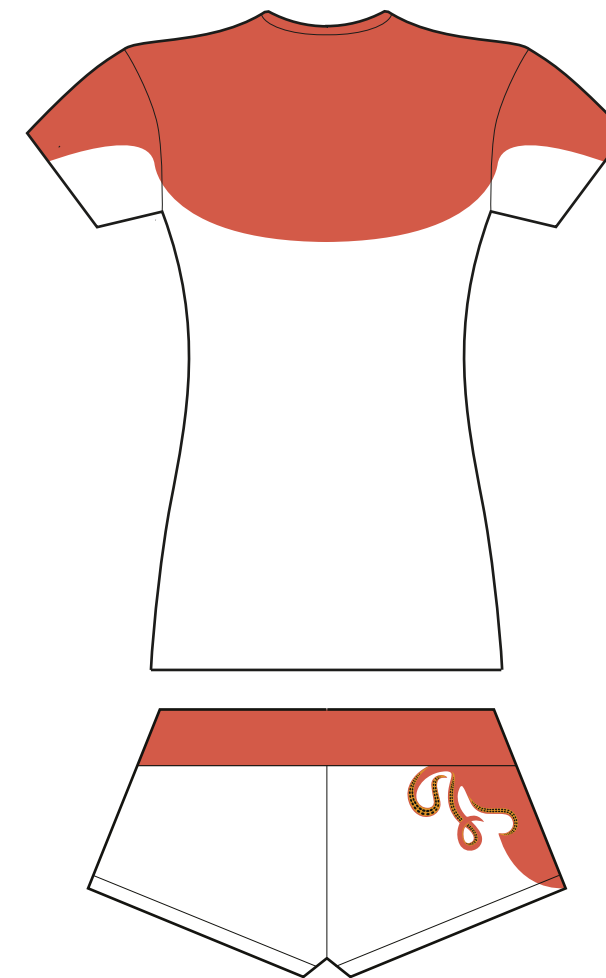

PACKAGING

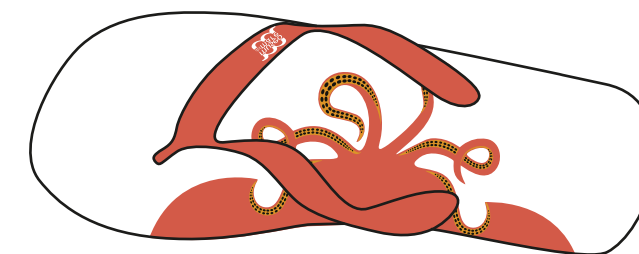
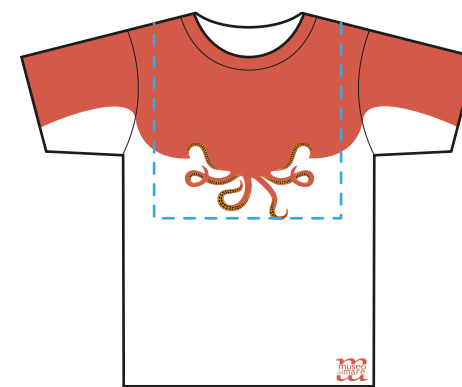

INFRADITO

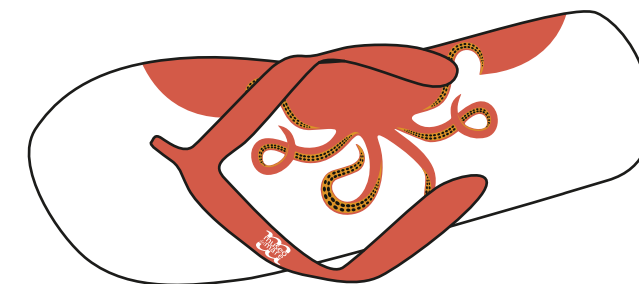



VELE SAMBENEDETTESI

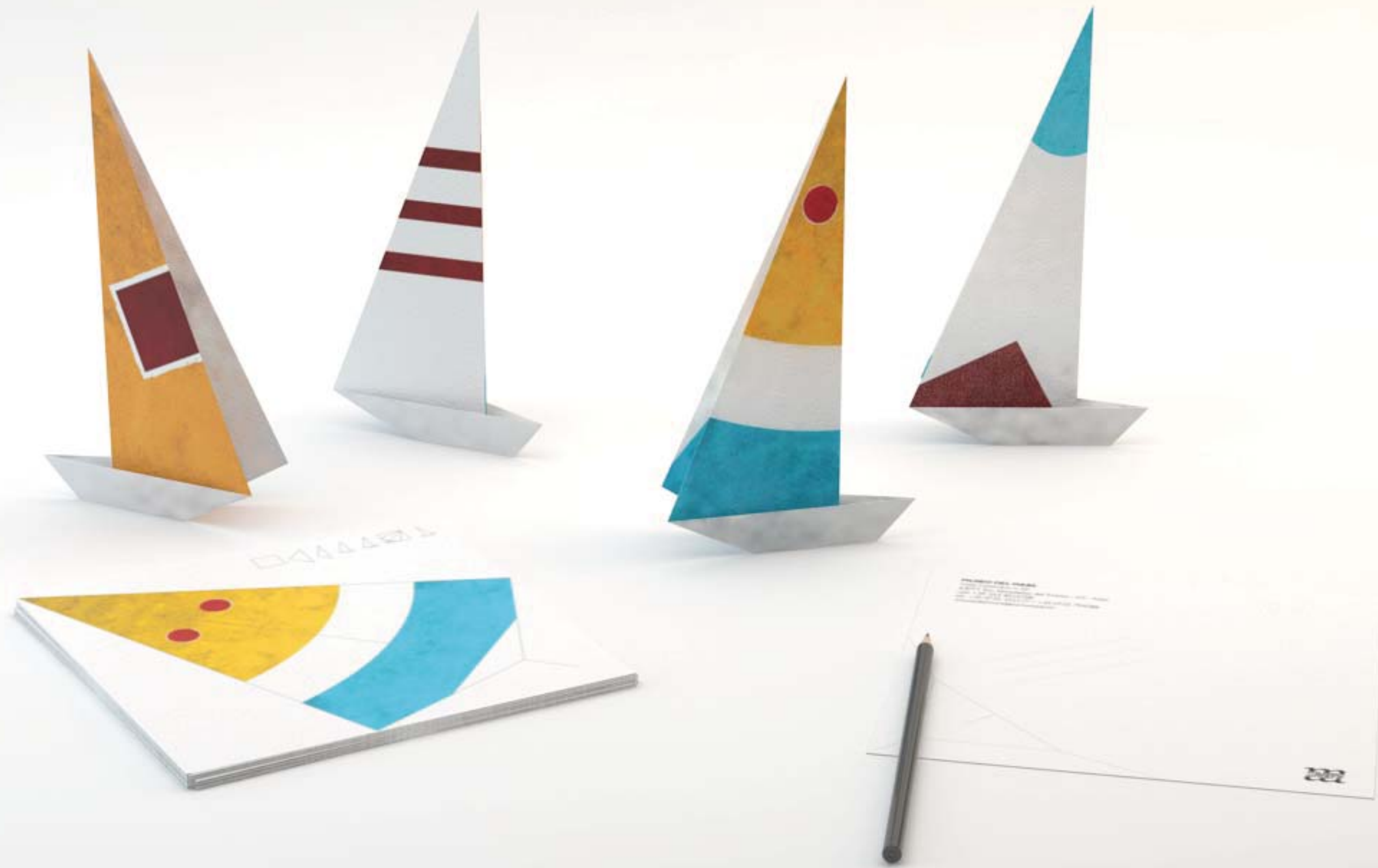

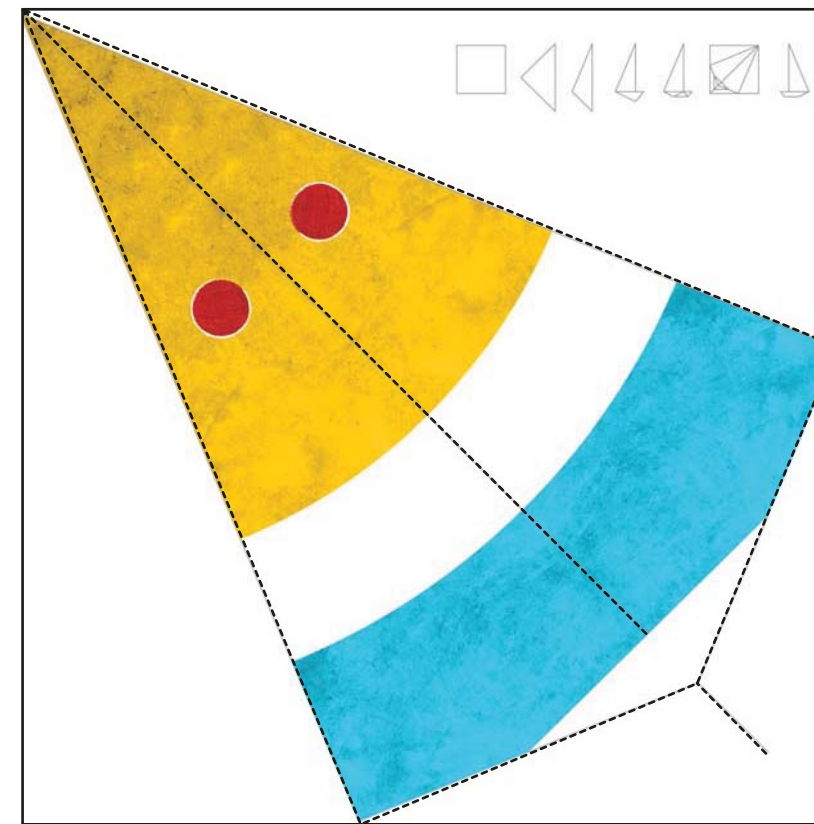

1

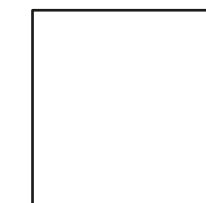

2

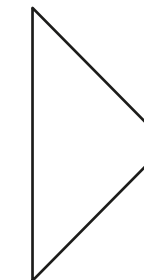

3



4



5



MUSEO DEL MARE
Viale Colombo n. 92
63074 San Benedetto del Tronto - AP - Italia
cell. +39 393 8925708
tel. +39 0735 592177 / +39 0735 794588
museodelmare@comunesbt.it



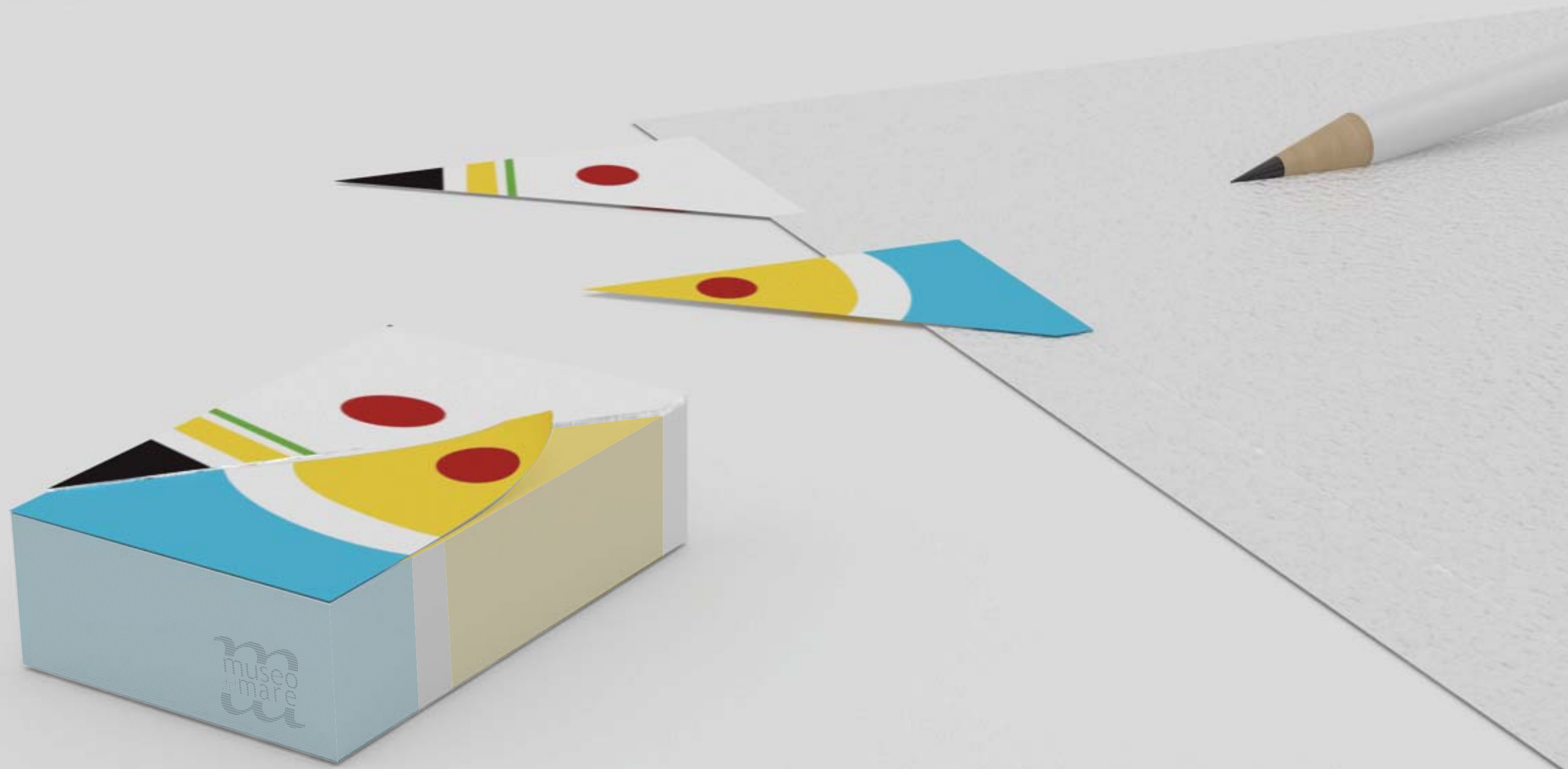

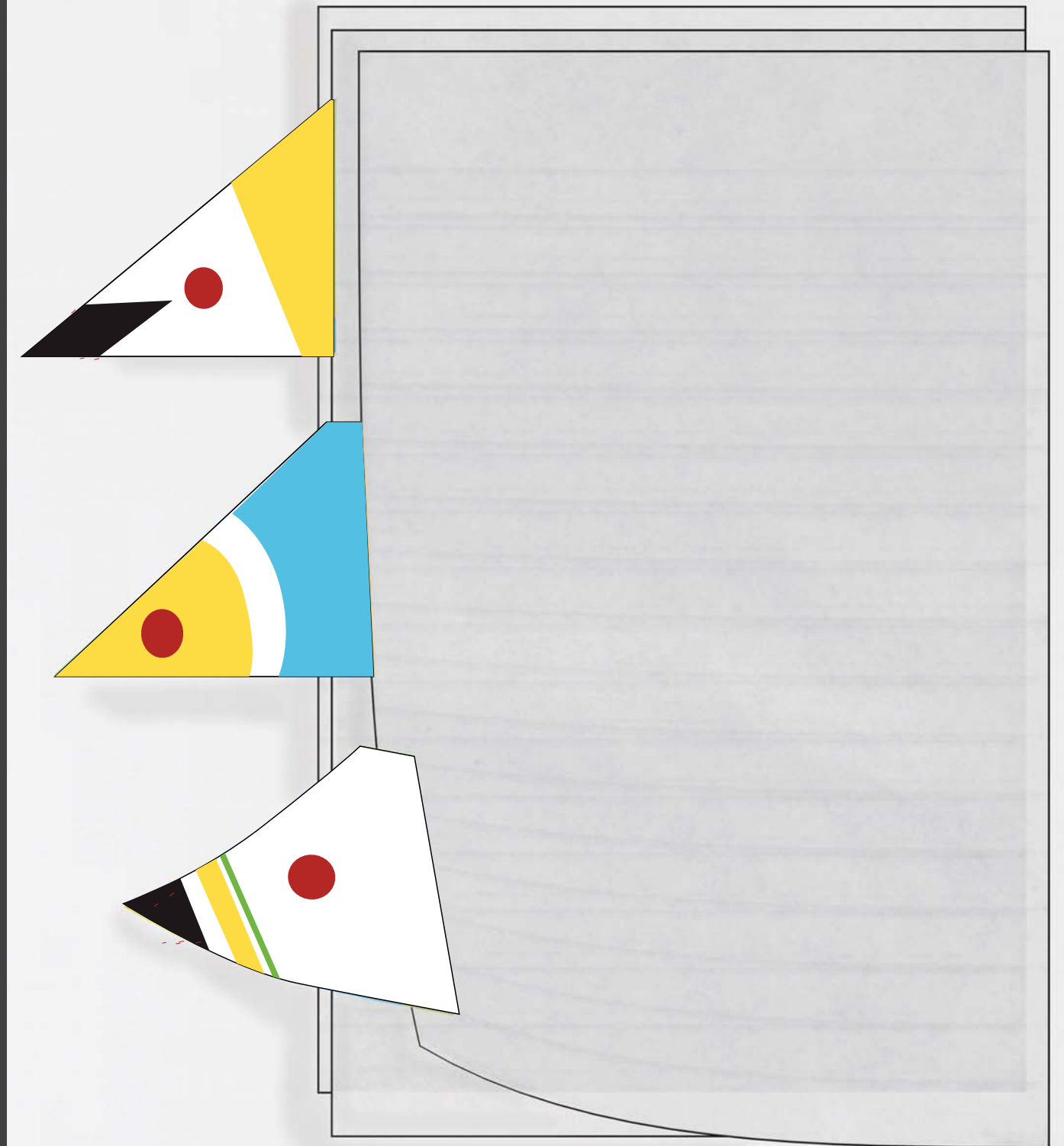
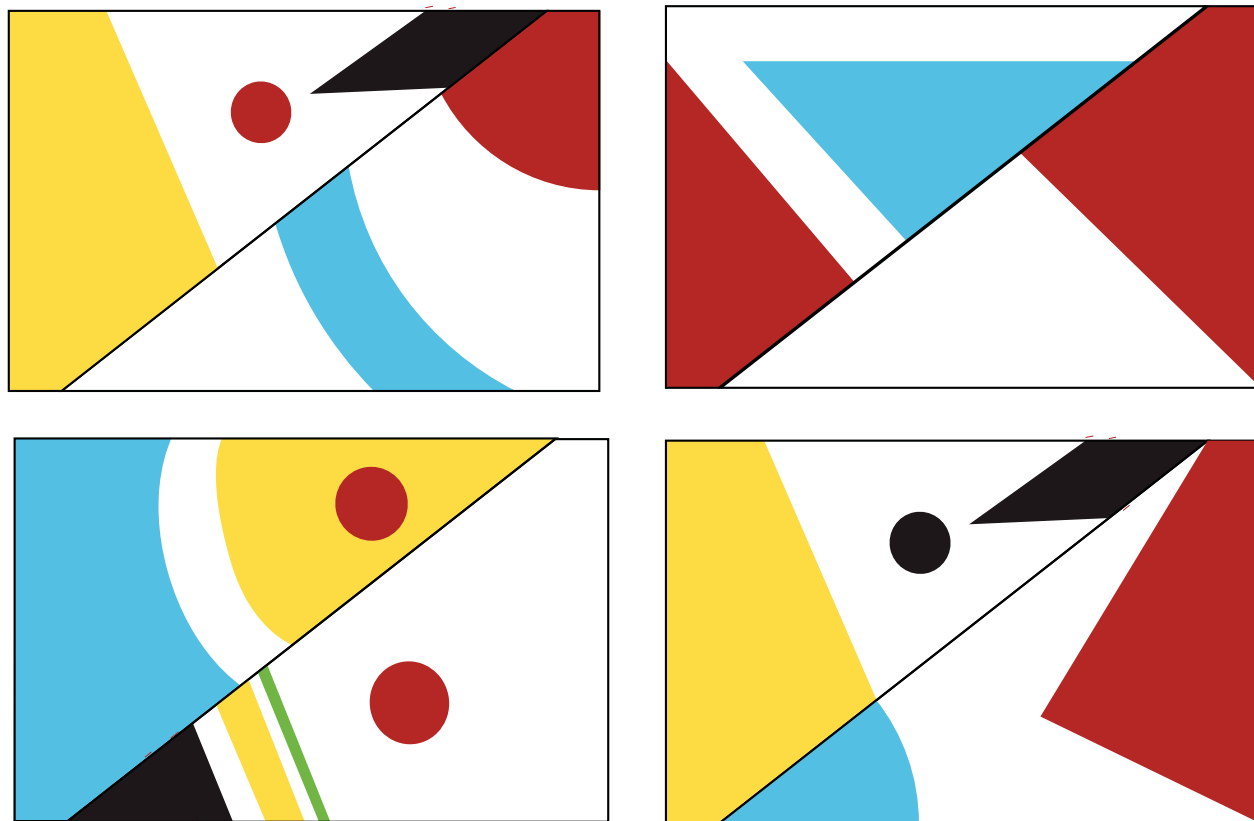
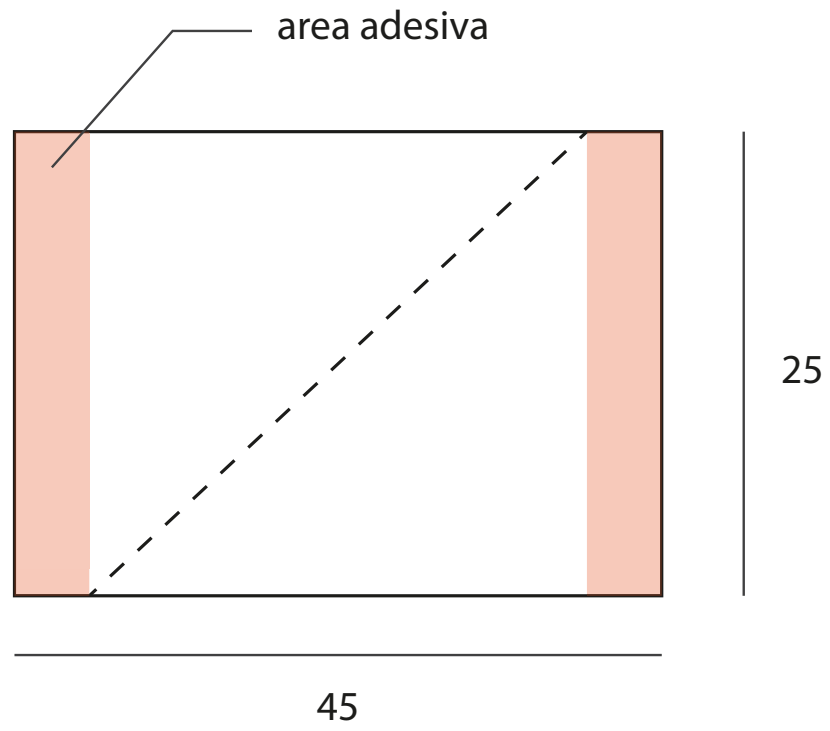

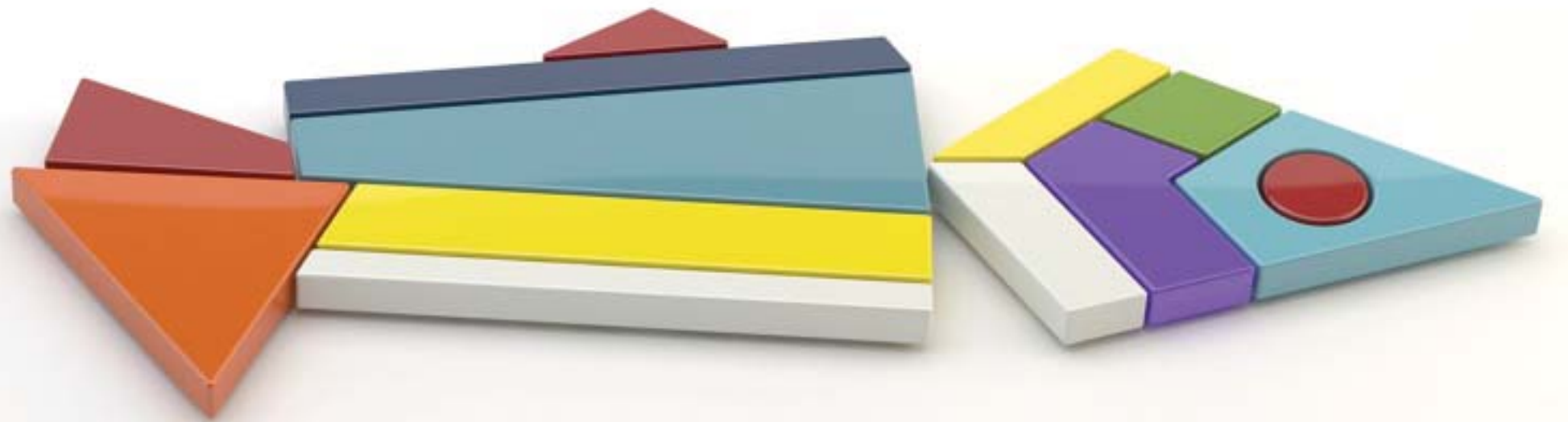
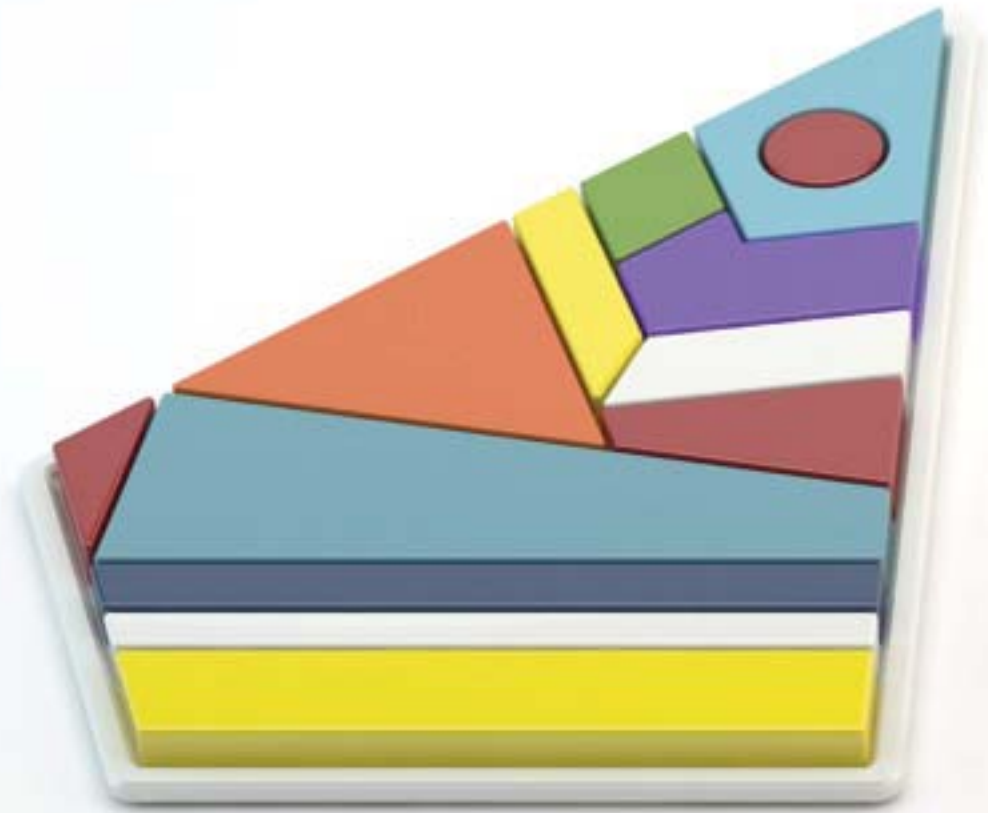

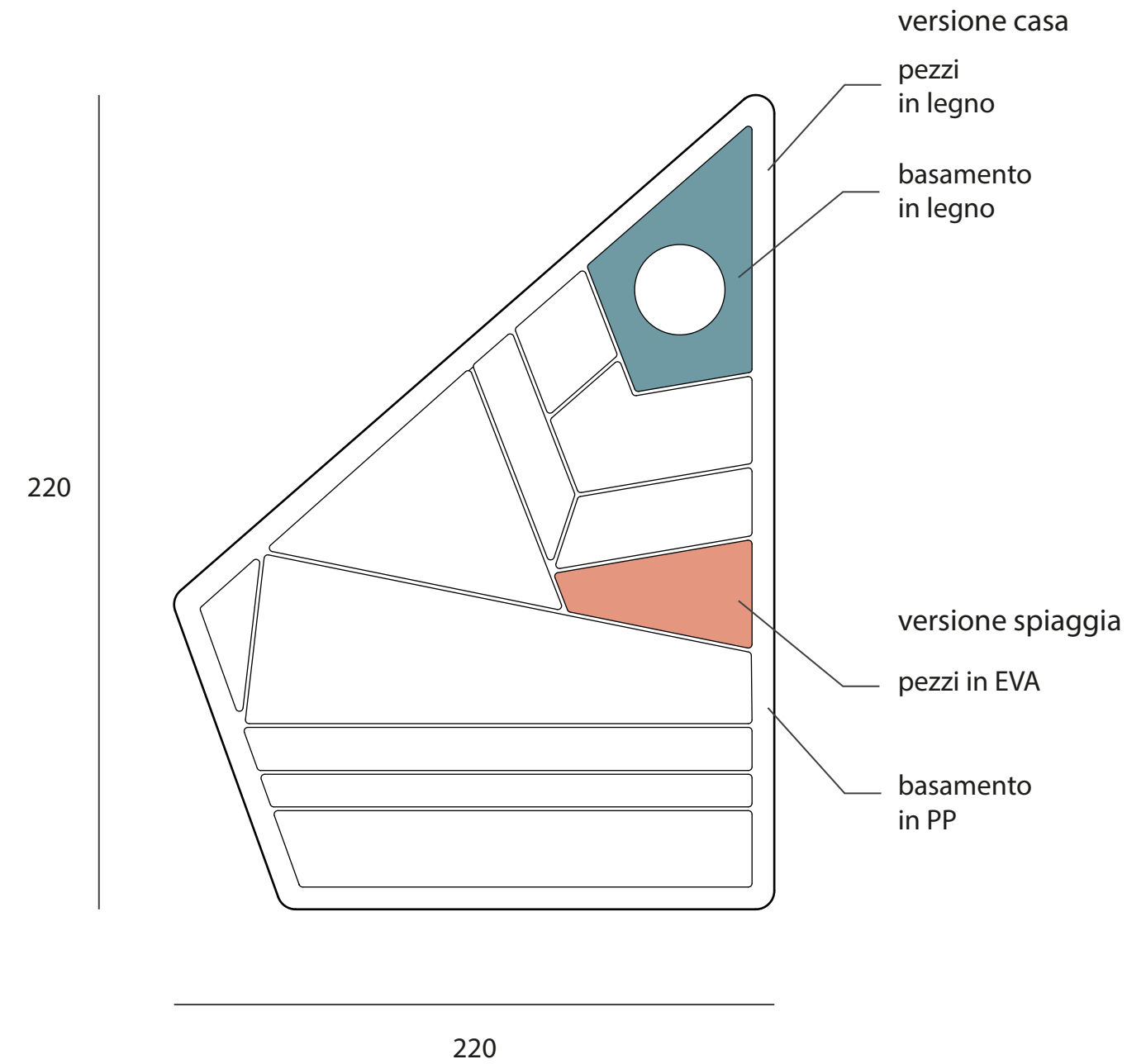
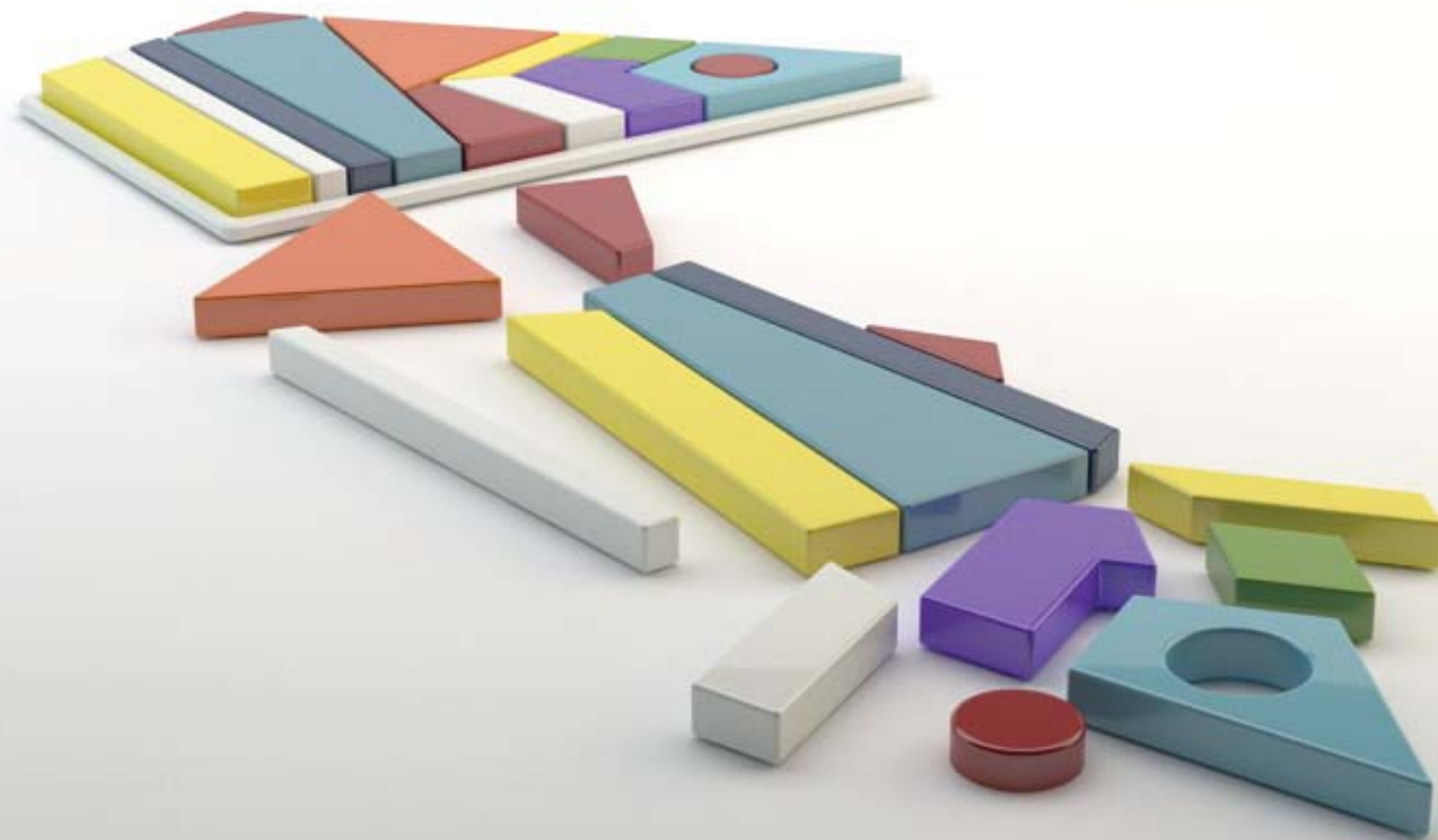



set tazze da caffè | casalinghi

set da 3pz

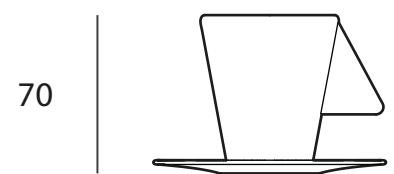
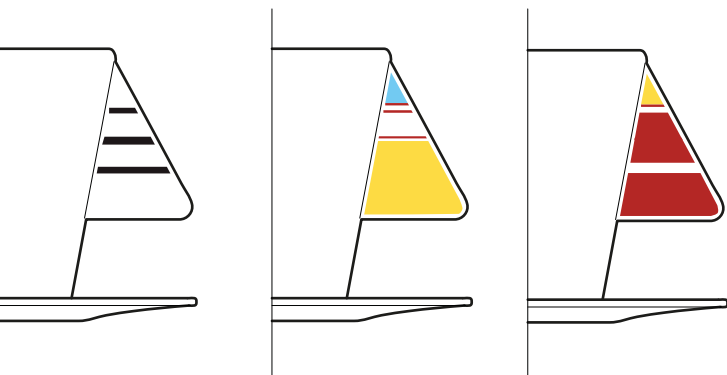

set da 4pz

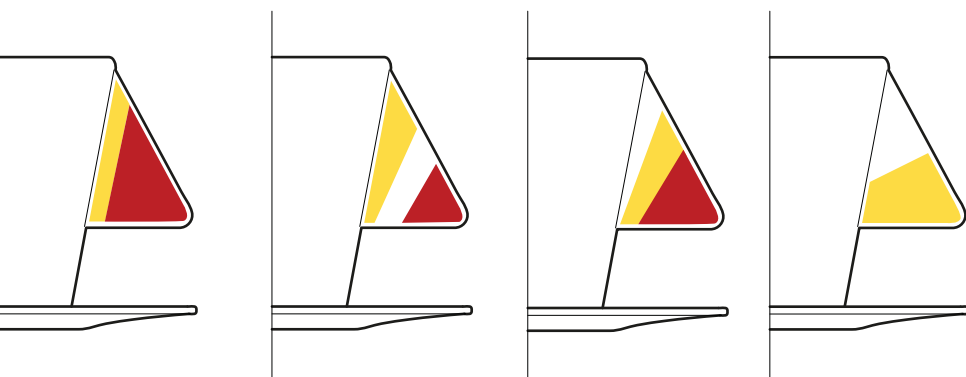

100

set da 6pz

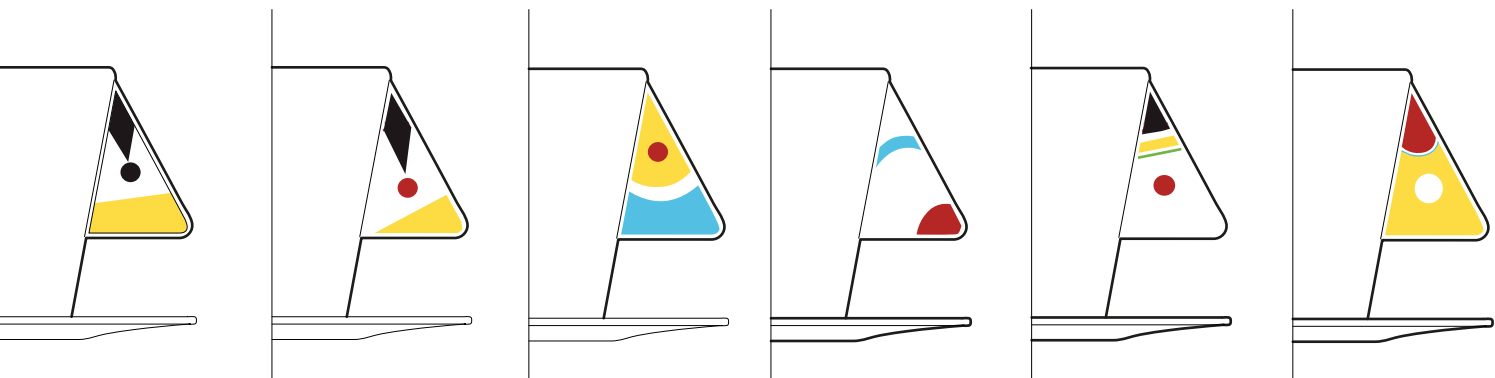



T-shirt vela | abbigliamento bambini

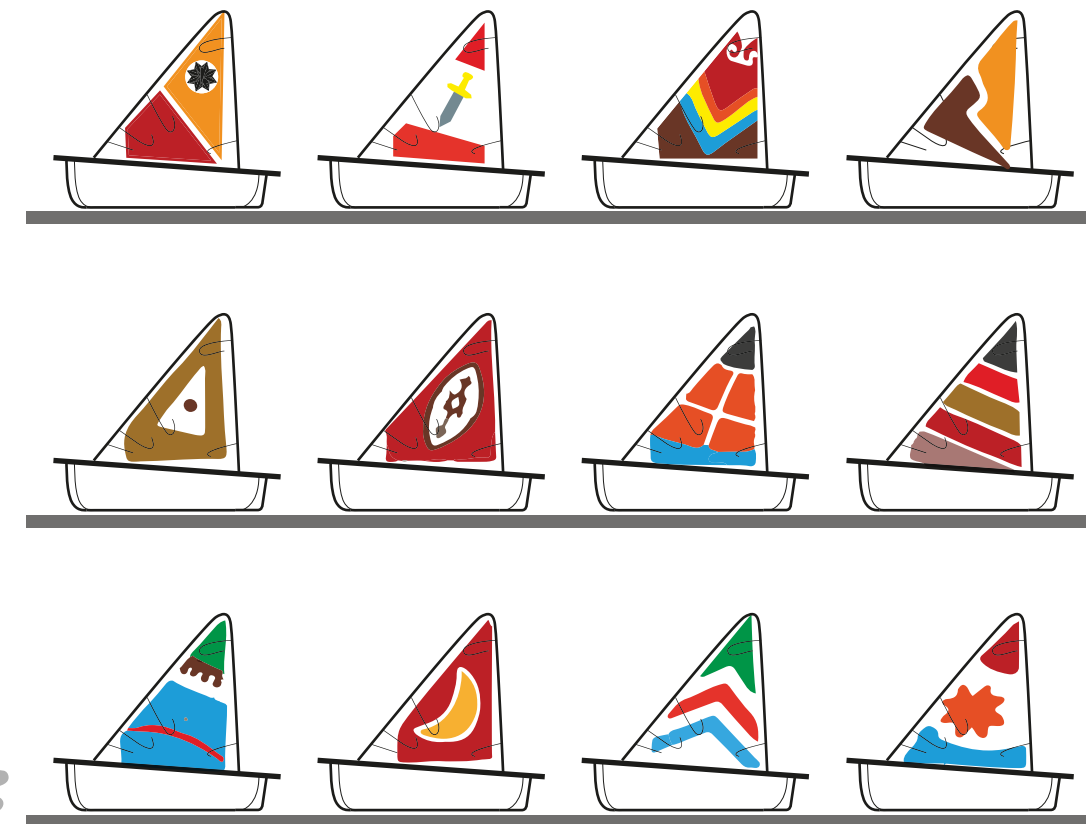
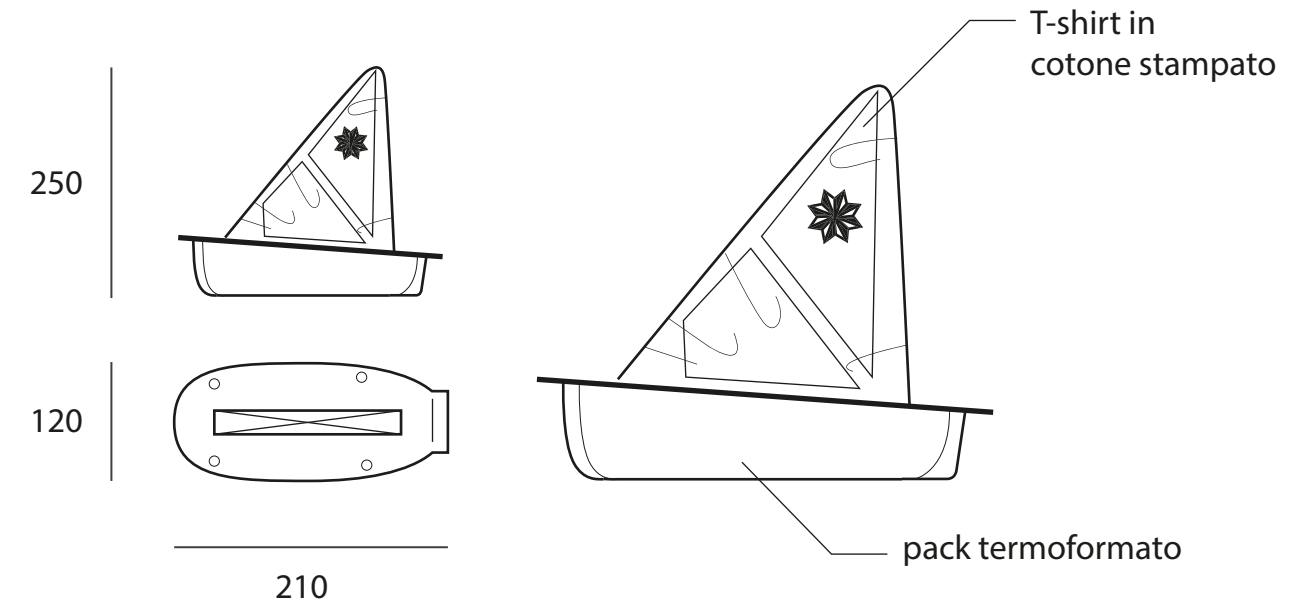
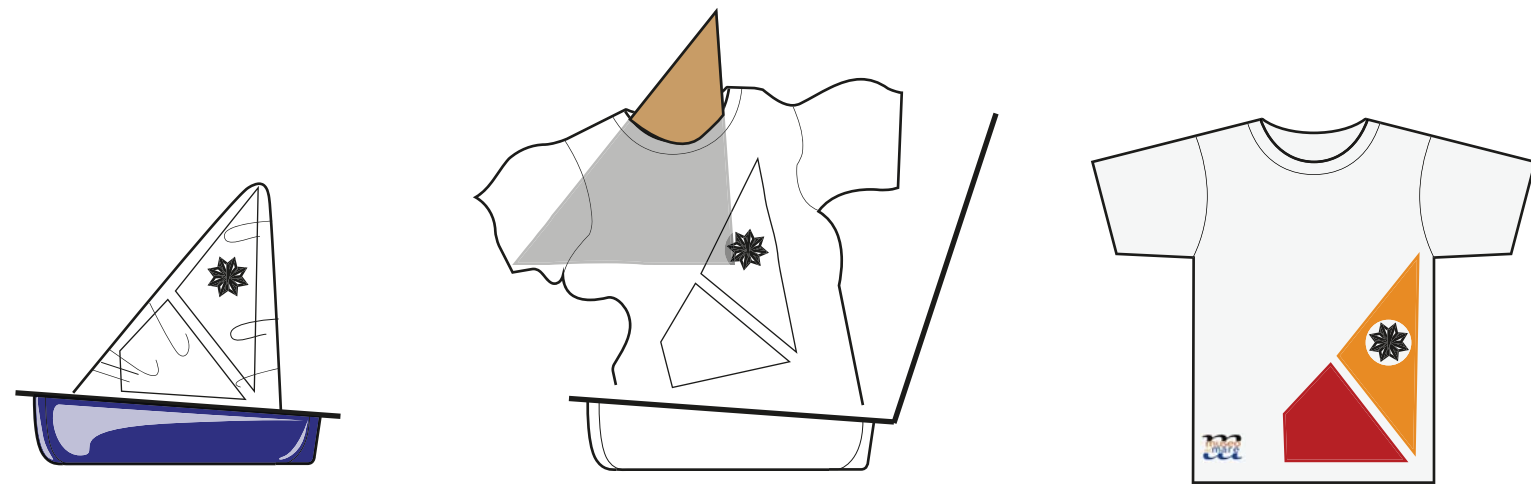

shopper in canapa/cotone | abbigliamento

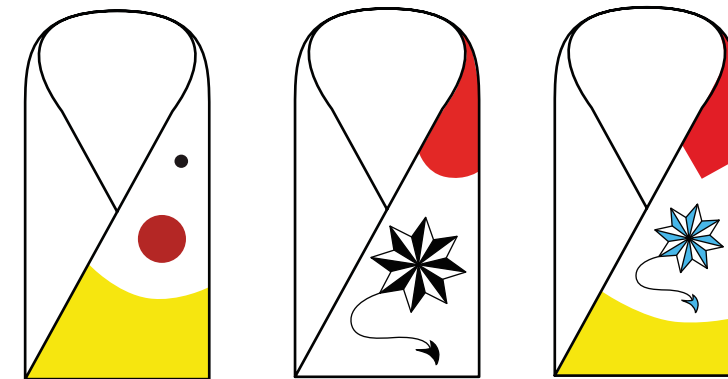
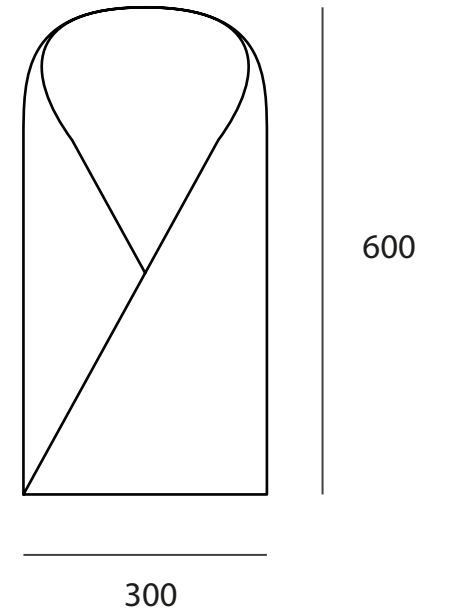

COLLEZIONE
WHITE

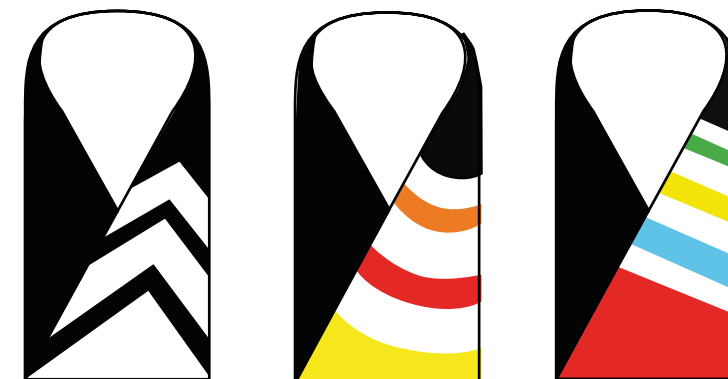

COLLEZIONE
BLACK



ANFORE



ANFORA
CANANEA

40

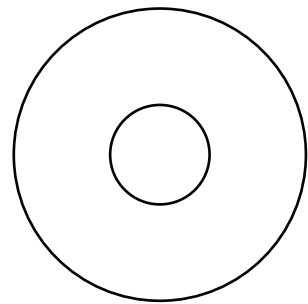

ANFORA
DRESSEL

57

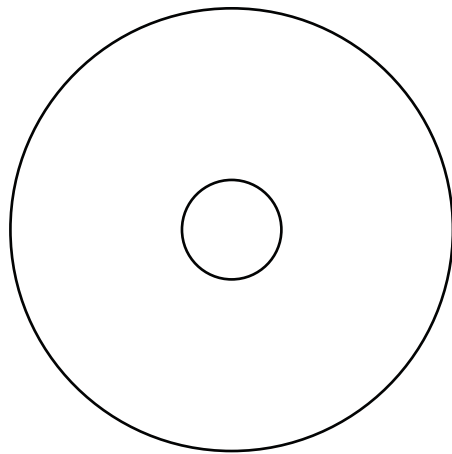

ANFORA
LAMBOGLIA

30

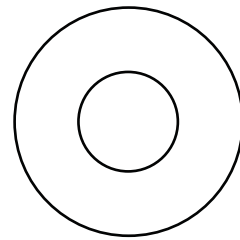

60

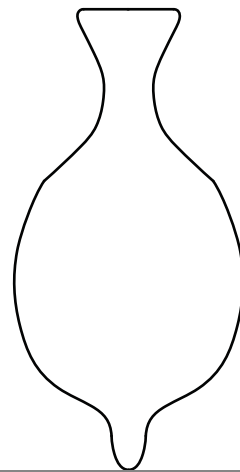
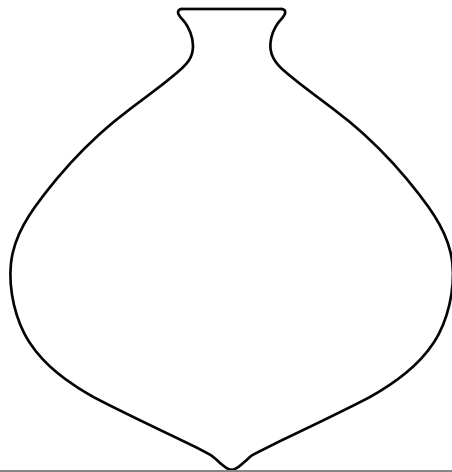
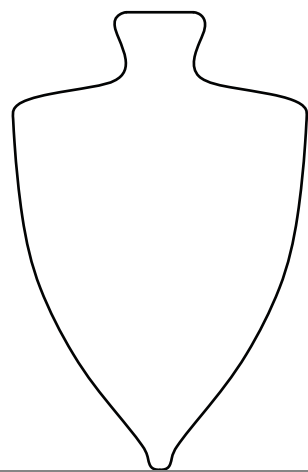



ANFORA PUNICA



ANFORA CANANEA



ANFORA DRESSEL



DRESSEL 30

ELEMENTS TIPOLOGICAL

Hard grey-buff (10YR 6/2) fabric with prominent angular white inclusions up to 1 mm across and an off-white slip on the outer surface.

A collection of tradition, values and territories, Museum of amphoras of San Benedetto del Tronto, Italy.

ANFORA CANANEA



ANFORA PUNICA



ANFORA DRESSEL





PARANZA



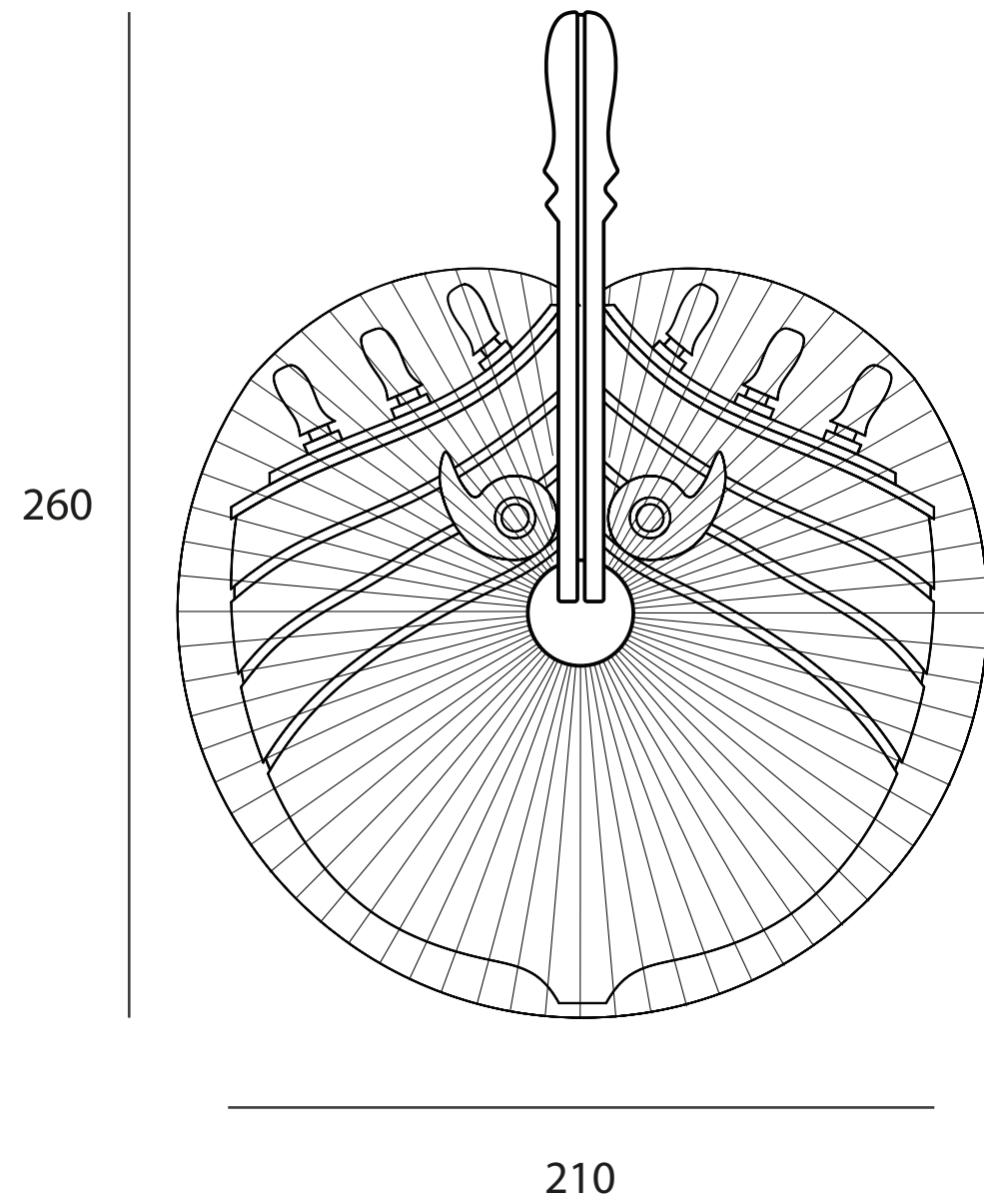



contenitori equipaggio della paranza | casalinghi

LU MERENILLE

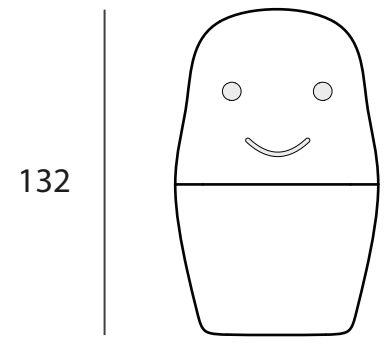

LU MERÈ

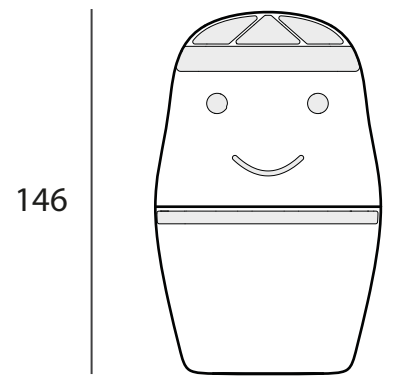

LU JVNETTE

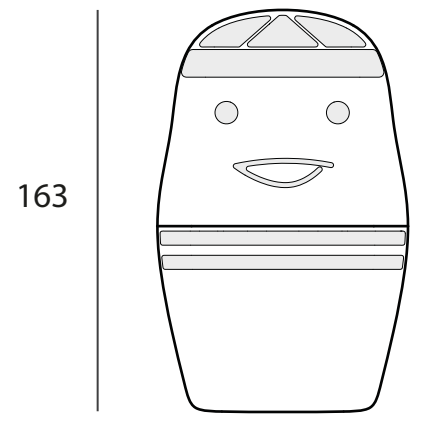

LU MARENARE

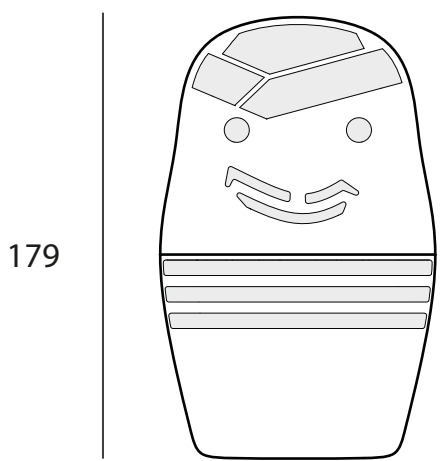

LU SOTTEPARÒ

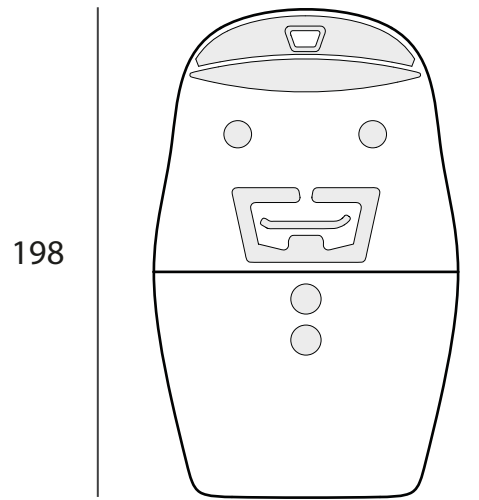

LU PARÒ

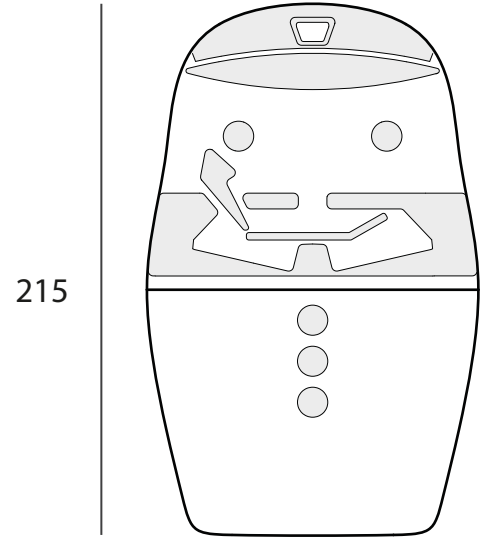

m
museo
del mare
u



LU MERENILLE

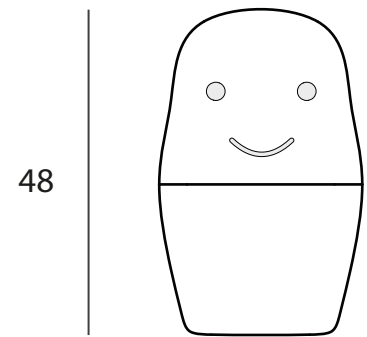

48

30

LU MERÈ

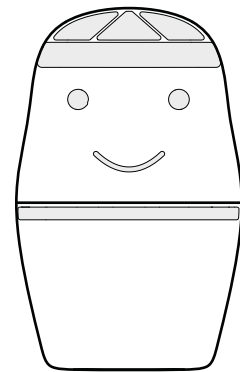

51

32

LU JVNETTE

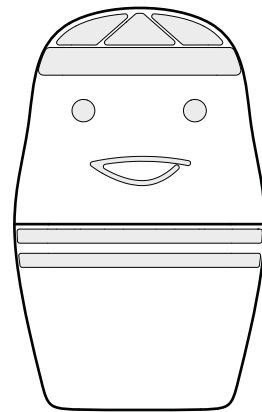

54

34

LU MARENARE

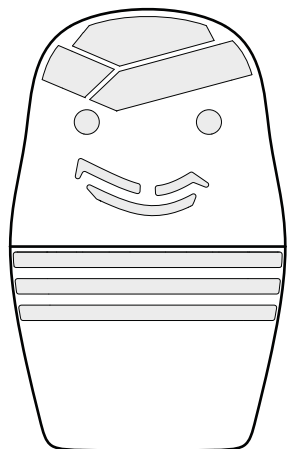

56

35

LU SOTTEPARÒ

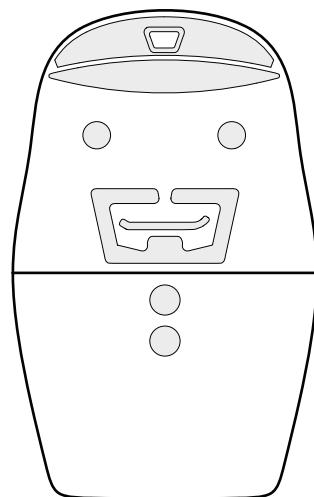

60

37

LU PARÒ

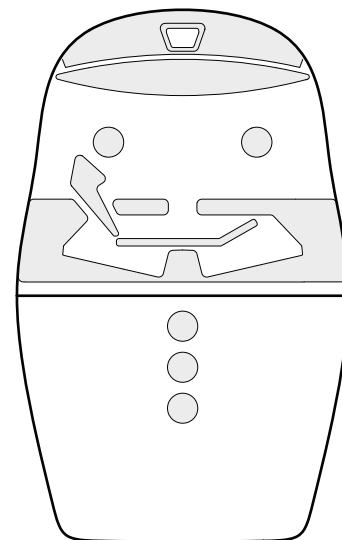

65

39



card paranza in realtà aumentata | giochi

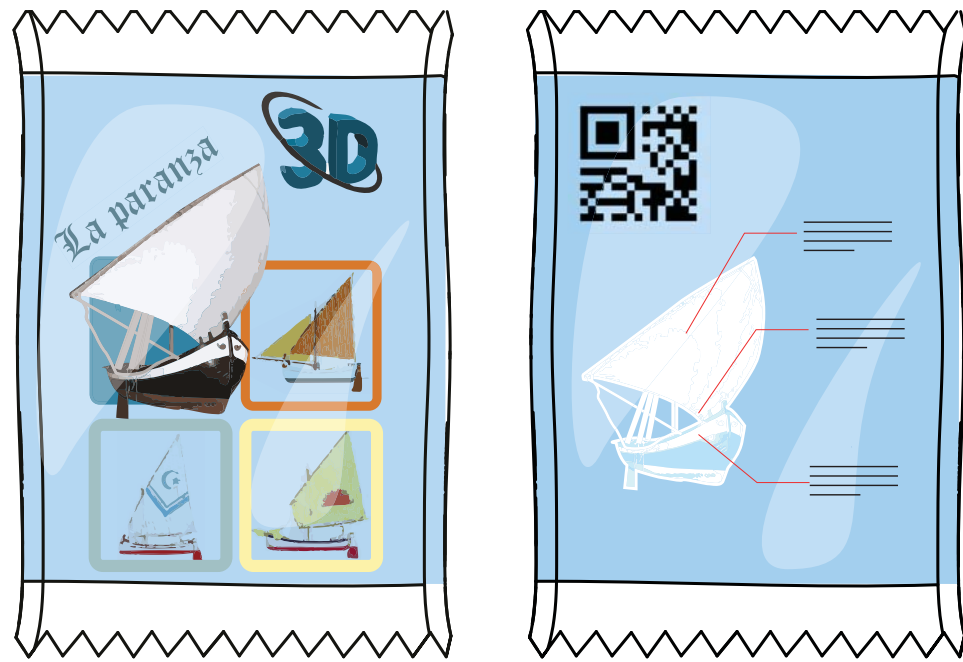

bustine collezionabili con varie tipologie di navi da pesca e con le vele tipiche sambenedettesi

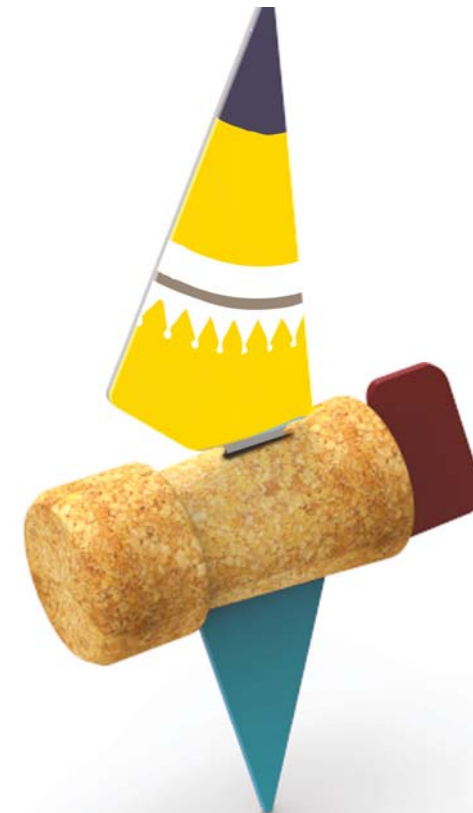
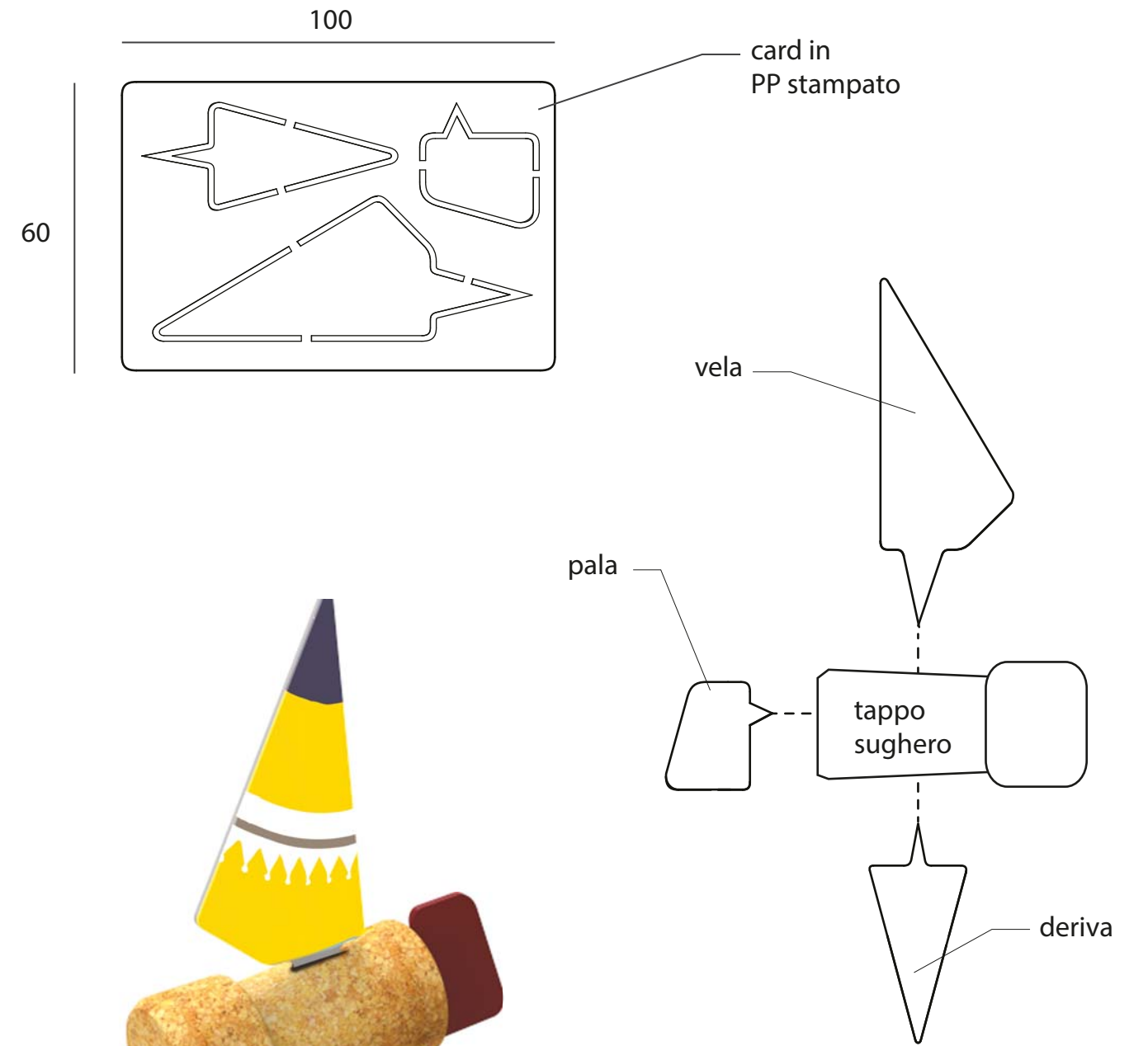

Da lu mare scappe, a la canténe rrintre

*Lu mije pèsce de mmare jè la zanchètte,
la mije giuventù a Sammenedètte*

*Sarba parò che lu vinte jè fresche,
l'arie se contrubbe e fa burrasca*

Arbé, da lu pòrte 'nen parté!

Sciròcche, uje tére dematéne scròcche!

*Jème a le Gròtte a magnà i ciuffelòtte,
jème a Marà a magnà lu baccalà*

DETTI DIALETTALI

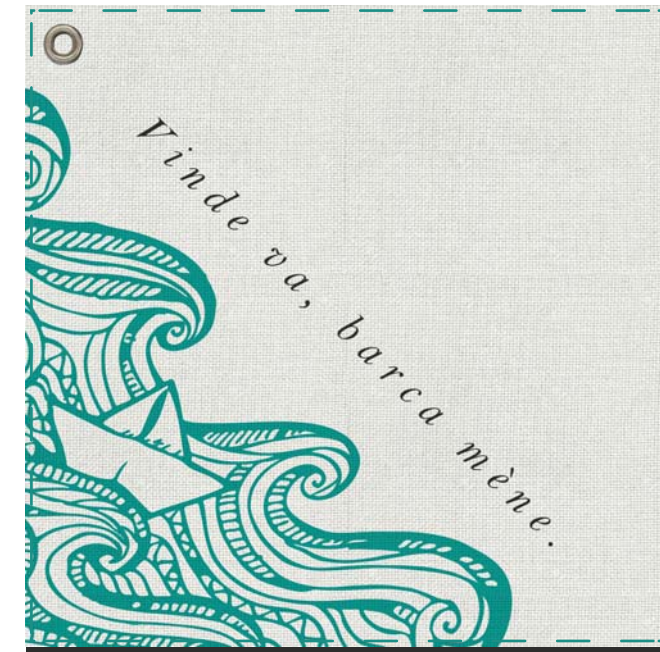

500

SERIE

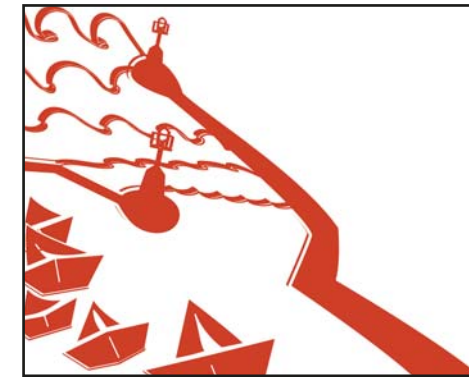
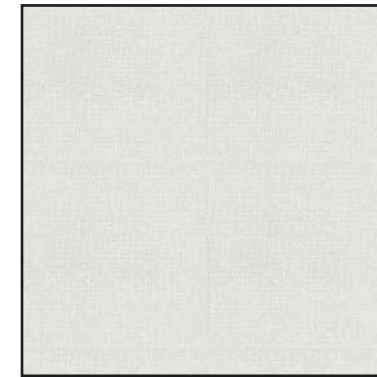

Arbè, da lu pòrte 'nen parté!

TARGHETTA

fronte



45

retro

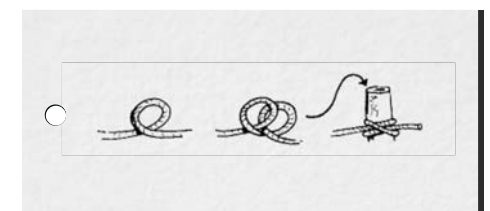

100





Jè da levante

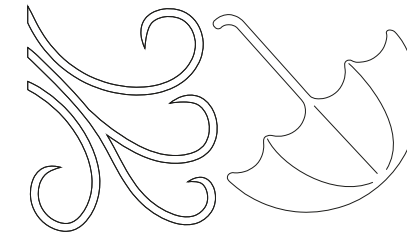

e piove

Da lu mare
scappe,

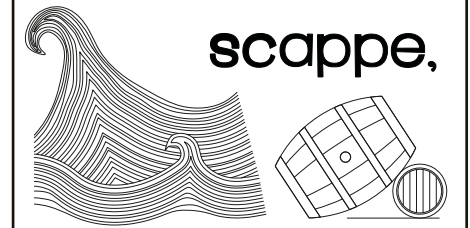

a la canténe
rrintre

Fréje lu pèsce

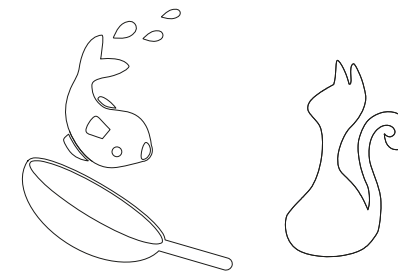

e 'uarde la 'atte

Barca péne,

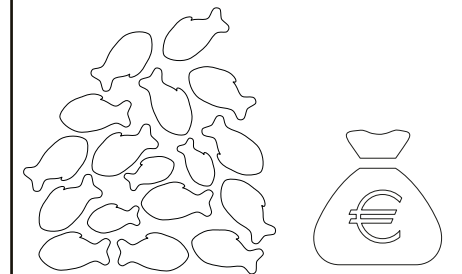

cónte fatte...



FORMELLE E SPOLETTA



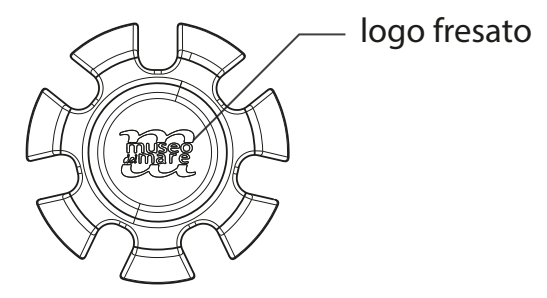
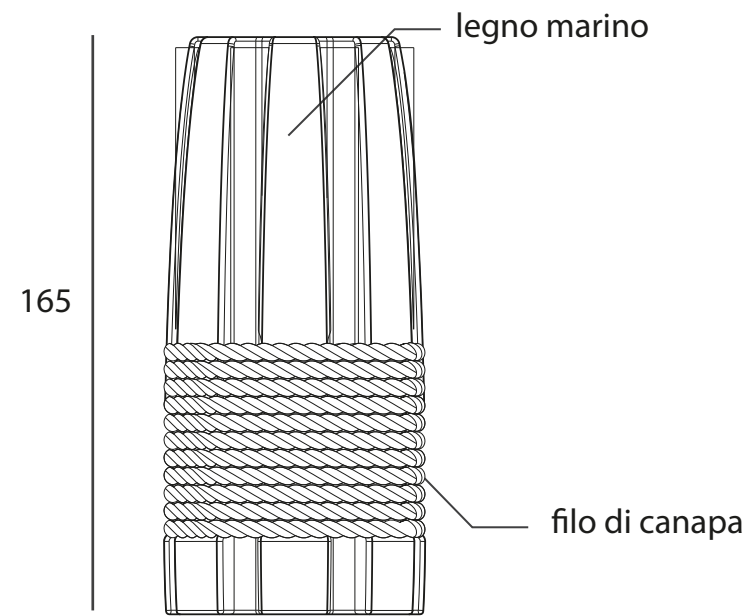

75

DIVERSE ESSENZE

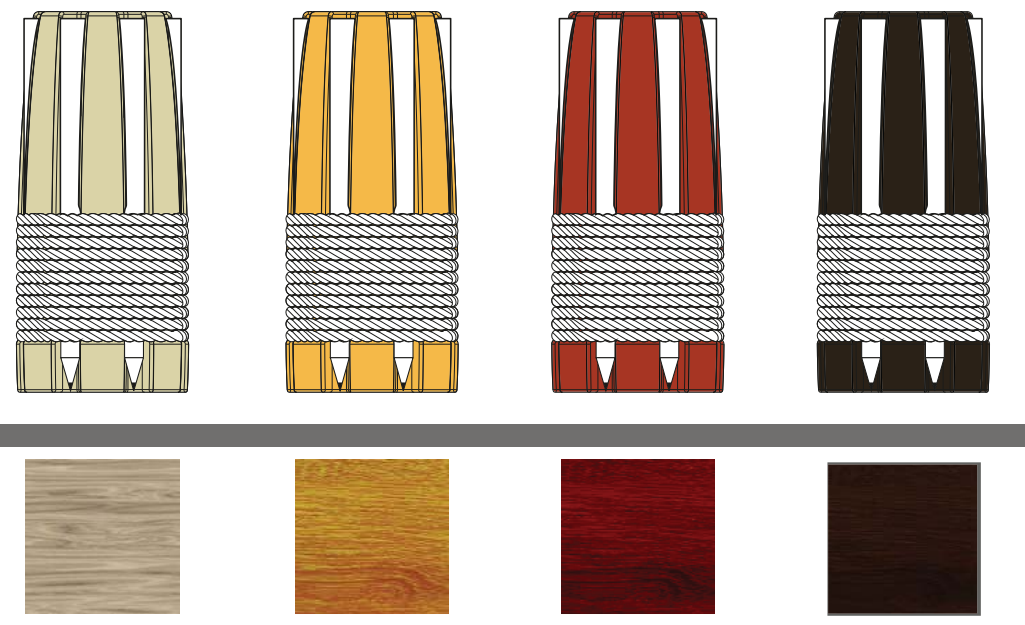





legno marino
spessore 4 mm

150

10

VARIANTI ESSENZE

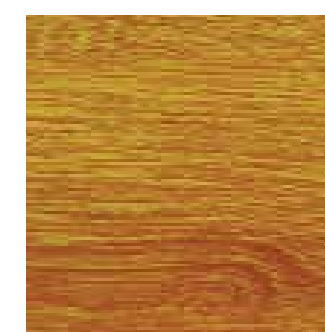



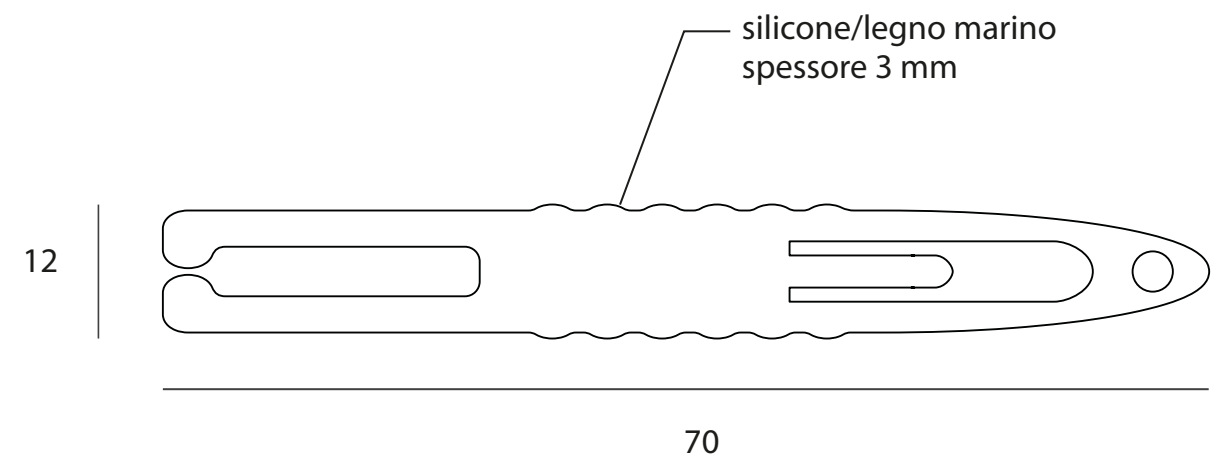

versione in silicone



versione in legno con nodi marinari

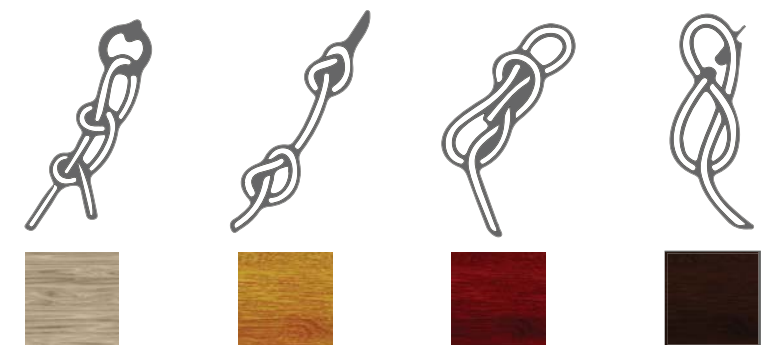
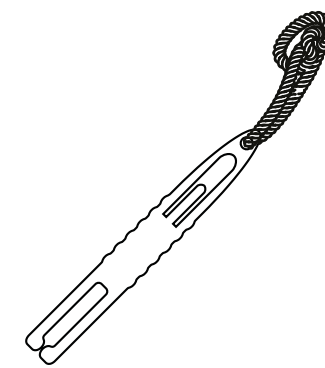



COLTELLO DEL RETARO



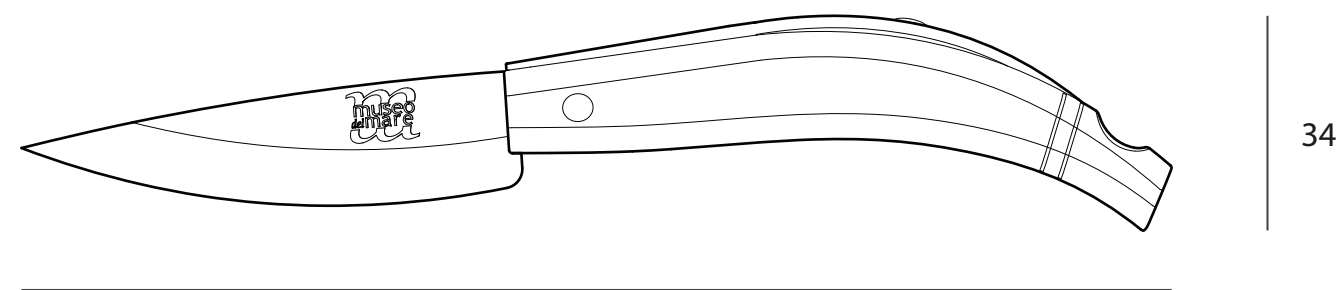

180

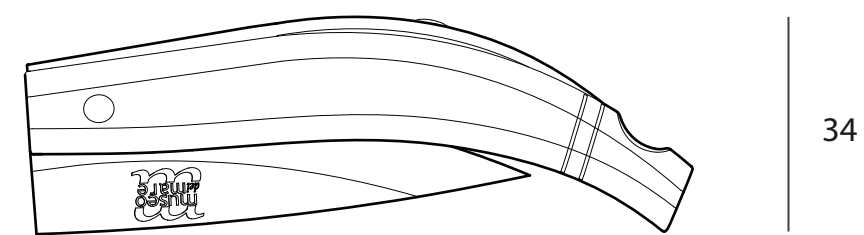

105



MASA



masa

centopercento sambenedettese

